



HAWKINS



STRIPCAT™ OWNER'S MANUAL

REVISED 01.21



This manual is applicable to: StripCat™

Record the model number and serial number of your StripCat™ along with date purchased:

MODEL NUMBER _____

SERIAL NUMBER _____

DATE PURCHASED _____

SERIAL NUMBER

The serial number plate is located on the frame to be readily available. It is suggested that your serial number and purchase date also be recorded above.

The serial number provides important information about your StripCat™ and may be required to obtain the correct replacement part. Always provide the model number and serial number to your Hawkins Ag dealer when ordering parts or anytime correspondence is made with Hawkins Ag.

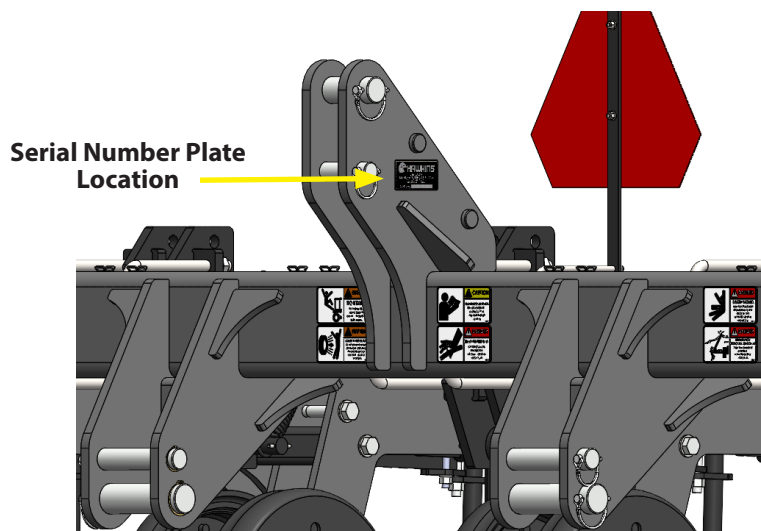



TO THE DEALER

Factory to Farm™ service includes full factory assembly. Dealer is responsible for field readiness.

PRE-DELIVERY CHECKLIST

Use the following checklist after your StripCat™ is completely assembled. Check off each item as it is found satisfactory or after proper adjustment is made.

- All working parts move freely, bolts are tight, and cotter pins are spread.
- Check for oil leaks and proper hydraulic operation.
- Hydraulic hoses correctly routed to prevent damage.
- Inflate tires to specified air pressure and torque wheel lug bolts and lug nuts as specified in the manual.
- All safety decals correctly located and legible. Replace if damaged.
- All reflective decals and SMV sign correctly located and visible when the machine is in transport position.
- Safety/warning lights correctly installed and working properly.
- Paint all parts scratched during shipment or assembly.
- All safety lockup devices on the StripCat™ are correctly located.

The StripCat™ has been thoroughly checked and to the best of my knowledge is ready for delivery to the customer.

(Signature Of Set-Up Person/Dealer Name/Date)

NAME _____ DELIVERY DATE _____

STREET ADDRESS _____ MODEL NO. _____ SERIAL NO. _____

CITY, STATE/PROVINCE _____ DEALER NAME _____

ZIP/POSTAL CODE _____ DEALER NO. _____



DELIVERY CHECKLIST

Use the following checklist after your StripCat™ is delivered as a reminder of very important information which should be conveyed to retail customer/end user. Check off each item as it is fully explained.

- Life expectancy of this or any other machine is dependent on regular lubrication as directed in the Owner's Manual.
- All applicable safety precautions.
- Along with retail customer/end user, check reflective decals and SMV sign are clearly visible with StripCat™ in transport position and attached to tractor. Check safety/warning lights are in working condition. Tell retail customer/end user to check federal, state/provincial, and local regulations before towing or transporting on a road or highway.
- Give Owner's Manual and all Instruction Sheets to retail customer/end user and explain all operating adjustments.
- Read warranty to retail customer/end user.
- Complete Warranty and Delivery Report form.

To the best of my knowledge, this machine has been delivered ready for field use and customer has been fully informed as to proper care and operation.

(Signature Of Set-Up Person/Dealer Name/Date)

AFTER DELIVERY CHECKLIST

The following is a list of items we suggest to check during the first season of use of the equipment.

- Check StripCat™ performance with retail customer/end user.
- Review importance of proper maintenance and adherence to all safety precautions with retail customer/end user.
- Check for parts that may need to be adjusted or replaced.
- Check all safety decals, reflective decals, and SMV sign are correctly located as shown in the Parts Guide and that decals are legible. Replace if damaged or missing.
- Check safety/warning lights are functioning properly.

(Signature Of Set-Up Person/Dealer Name/Date)

All registrations must be submitted to AGROdeviate within 5 business days of delivery. Retain a copy of this form for auditing purposes.

All registrations must be submitted to:

AGROdeviate
124 W 25th St. Ste C5
Kearney, NE 68847



GENERAL INFORMATION

HOW TO USE THIS MANUAL.....	1
WARRANTY INFORMATION	2
SAFETY	3
SIGNAL WORDS.....	3
EQUIPMENT SAFETY GUIDELINES	4

SAFETY

SAFETY SIGN LOCATIONS.....	5
SAFETY SIGN CARE.....	10

PREPARATION & SET-UP

POST DELIVERY/SEASONAL/PRE-TILLAGE SET-UP	11
CHECK/CHANGE HITCH CONFIGURATION	12
HITCHING TRACTOR TO IMPLEMENT.....	14
HYDRAULIC HOSE HOOK-UP	15
LIGHT KIT GUIDE AND RELOCATION	16
ELECTRICAL HOOK-UP	17
LEVELING THE IMPLEMENT	18

OPERATION

BEFORE FIRST USE	19
WING LOCK PINS.....	21
FOLDING/UNFOLDING FUNCTION.....	22
TRANSPORT CHECKLIST	24
LEVELING THE MACHINE	25
GAUGE WHEEL ADJUSTMENT	26
DOWN PRESSURE SPRINGS	27
ROW UNIT DEPTH/ADJUSTMENT.....	28
KNIFE PLATE.....	30
RESIDUE MANAGER	31
ROW CONFIGURATIONS	32
INDEPENDENT BERM BUILDERS.....	33
REAR FINISHING TOOLS	39
HYDRAULIC TRIPPING UNIT.....	40
BAR STANDS.....	43
OPERATING TIPS/OPERATING SPEED	44
PARKING/STORAGE	46
DO'S AND DON'TS	48

TROUBLESHOOTING

TROUBLESHOOTING	49
-----------------------	----

MAINTENANCE & LUBE

GENERAL MAINTENANCE.....	52
MAINTENANCE SCHEDULE	53
BLEEDING FOLD HYDRAULICS	54
BOLT TORQUE CHART	55
HYDRAULIC FITTING IDENTIFICATION	56

PARTS GUIDE

TOOLBAR MOUNT & PARALLEL LINKAGE	58
SIDEPLATE & ROW CLEANER STEM	60
FRONT COULTER	61
DEPTH GAUGE WHEEL.....	62
INDEPENDENT BERM BUILDER.....	63
KNIFE PLATE.....	67
REAR ACCESSORY MOUNT.....	68
REAR FINISHING TOOLS	69
ROW CLEANER ASSEMBLIES	72
HYDRAULIC TRIPPING SYSTEM.....	74
STRIP FRESHENER DISC ASSEMBLY.....	82

GENERAL INFORMATION



HOW TO USE THIS MANUAL

This manual is divided into sections. The first section contains a Table of Contents, General Information, and a Part Number Index. The remaining sections divide the machine into assemblies and sub-assemblies which illustrate and list all parts.

Hawkins Ag parts in this manual are specially designed for this machine and should be replaced with Hawkins Ag parts only.

Information in this manual was current at time of printing. However, due to Hawkins Ag's ongoing product improvement, production changes may cause your machine to appear slightly different in detail. Hawkins Ag reserves the right to change specifications or design without notice and without incurring obligation to install the same on machines previously manufactured.

Right-hand and left-hand as used in this manual are determined by facing the direction the machine will travel while in use.

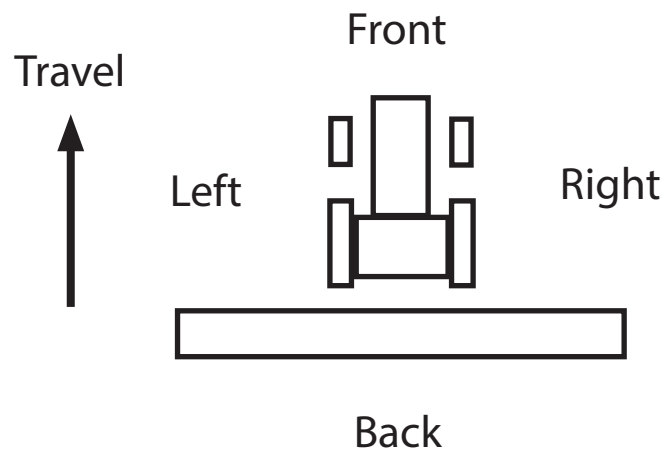

MANUAL REPLACEMENT INFORMATION

Replacement manuals are available. Call the Hawkins Ag Main Office at 308.708.8185, or download a printable PDF from our website, www.hawkinsag.com.

MANUAL REVISIONS

When this manual is revised, the modification date is printed on the front cover and on the revised page(s).

TOUCH-UP PAINT

Repaint parts where paint is worn or scratched to prevent rust. Aerosol touch-up paint is available. To order, call Hawkins Ag at 308.708.8185.



INTRODUCTION

Thank you for your purchase of a Hawkins Ag StripCat™. Putting your trust in our equipment is something we don't take lightly and are humbled that you chose Hawkins Ag. Having designed all of our equipment with farmers like you in mind, we hope you enjoy years of productive use from it. Please read and understand this manual before operation.

WARRANTY INFORMATION

AGROdeviate LLC (AGROdeviate) warrants each Hawkins Ag product it manufactures to be free from defects in material and workmanship for a period not to exceed one (1) year from the date of sale to the original owner. The warranty is valid provided written notice of the alleged defect is received by AGROdeviate during said period and within ten (10) working days after its discovery.

In addition, AGROdeviate warrants each TOOLBAR FRAMEWORK to be free from defects in material and workmanship for a period not to exceed three (3) years from the date of sale to the original owner. The warranty is valid providing written notice of the alleged defect is received by AGROdeviate during said period and within ten (10) working days after its discovery.

This warranty is subject to completion of Product Registration and submission to AGROdeviate. Warranty applies only if product is installed, operated, and maintained according to product manual and instructions. Warranty will be void if the product has been subject to misuse, misapplication, neglect, collision with obstruction, or alteration.

For products, parts, and components NOT manufactured by AGROdeviate, the warranty obligations of AGROdeviate shall be limited to the Original Equipment Manufacturers' warranty. Tires on AGROdeviate equipment are warranted through the respective tire manufacturer and their network of dealers.

All returns must be pre-approved by AGROdeviate and authorization issued before return. All returns must include a copy of the original invoice in order to be processed. Any returns without a copy of the original invoice will not be eligible to receive credit.

If determined that the product is defective in material and/or workmanship, the necessary parts will be replaced and/or repaired. All warranty repair or labor is to be performed by an AGROdeviate authorized party. AGROdeviate obligation under this warranty shall be limited to repairing or replacing parts deemed defective. Warranty does not cover travel expenses. AGROdeviate will bear no other costs including loss, incurred labor, rental fees, nor other.

All returns shall be pre-paid. If warranty is approved by AGROdeviate, return freight will be credited.

This warranty by AGROdeviate LLC is expressly in lieu of all other warranties, expressed or implied, including warranty of merchantability and fitness for use. We neither assume, nor authorize, any other entity to accept for us any liability relating to the sale of our products.



SAFETY

TAKE NOTE! THIS SAFETY ALERT SYMBOL FOUND THROUGHOUT THIS MANUAL IS USED TO CALL YOUR ATTENTION TO INSTRUCTIONS INVOLVING YOUR PERSONAL SAFETY AND THE SAFETY OF OTHERS. FAILURE TO FOLLOW THESE INSTRUCTIONS CAN RESULT IN INJURY OR DEATH.



**THIS SYMBOL MEANS:
-ATTENTION!
-BECOME ALERT!
-YOUR SAFETY IS INVOLVED!**

SIGNAL WORDS: Note the use of signal words DANGER, WARNING, and CAUTION with the safety messages. The appropriate signal word for each has been selected using the following guidelines:



DANGER: Indicates an imminently hazardous situation that, if not avoided, will result in death or serious injury. This signal word is to be limited to the most extreme situations typically for machine components which, for functional purposes, cannot be guarded.



WARNING: Indicates a potentially hazardous situation that, if not avoided, could result in death or serious injury, and includes hazards that are exposed when guards are removed. It may also be used to alert against unsafe practices.



CAUTION: Indicates a potentially hazardous situation that, if not avoided, may result in minor or moderate injury. It may also be used to alert against unsafe practices.

If you have questions not answered in this manual, require additional copies, or the manual is damaged, please contact AGROdeviate, 124 W 25th St. Ste C5, Kearney, NE, 308.708.8185, or visit our website: www.hawkinsag.com.



SAFETY... YOU CAN LIVE WITH IT!



EQUIPMENT SAFETY GUIDELINES

Safety of the operator is one of the main concerns in designing and developing a new piece of equipment. Designers and manufacturers build in as many safety features as possible. However, every year many accidents occur which could have been avoided by a few seconds of thought and a more careful approach to handling equipment. You, the operator, can avoid many accidents by observing the following precautions in this section. To avoid personal injury, study the following precautions and insist those working with you, or for you, follow them.

In order to provide a better view, certain photographs or illustrations in this manual may show an assembly with a safety shield removed. However, equipment should never be operated in this condition. Keep all shields in place. If shield removal becomes necessary for repairs, replace the shield prior to use.

Replace any CAUTION, WARNING, DANGER or instruction safety decal that is not readable or is missing. Location of such decals is indicated in this booklet.

Do not attempt to operate this equipment under the influence of drugs or alcohol.

Review the safety instructions with all users annually.

This equipment is dangerous to children and persons unfamiliar with its operation. The operator should be a responsible adult familiar with farm machinery and trained in this equipment's operations. Do not allow persons to operate or assemble the unit until they have read this manual and have developed an understanding of the safety precautions and how it works.

To prevent injury or death, use a tractor with a Rollover Protective Structure (ROPS). Do not paint over, remove or deface any safety signs or warning decals on your equipment. Observe all safety signs and practice the instructions on them.

Never exceed the limits of a piece of machinery. If its ability to do a job, or to do so safely, is in question - DON'T TRY IT.



SAFETY SIGN LOCATIONS

These types of Safety Signs and locations on the equipment are shown in the illustrations below. Good safety requires that you familiarize yourself with the various Safety Signs, the type of warning and the area, or particular function related to that area, that require your SAFETY AWARENESS.

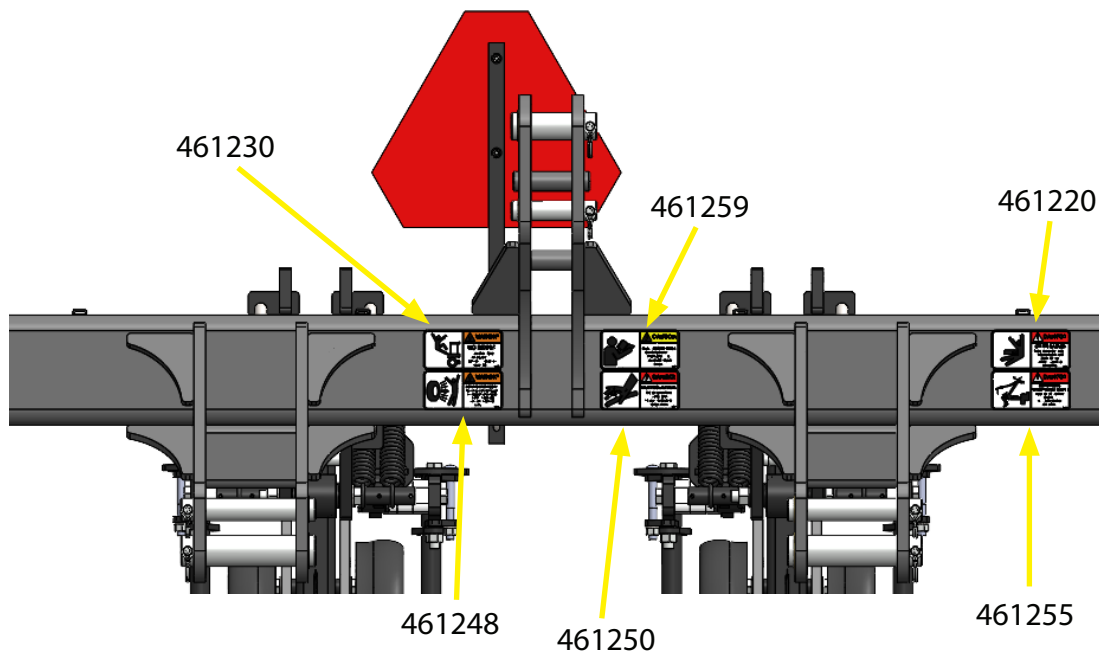

NOTE: LH/RH Safety Signs and locations are similar

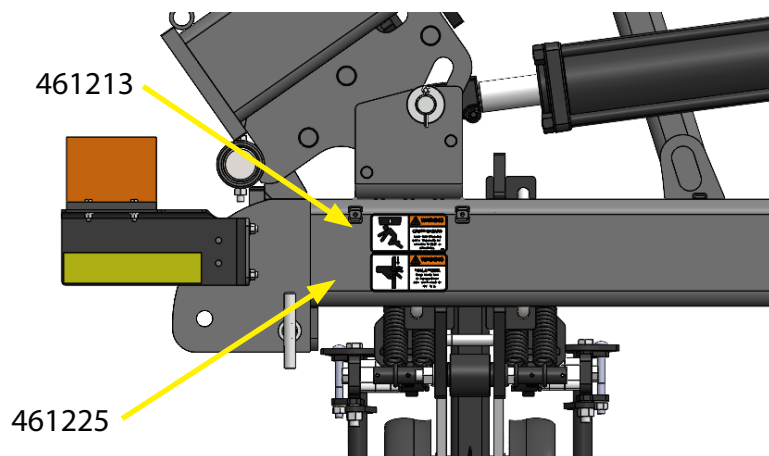

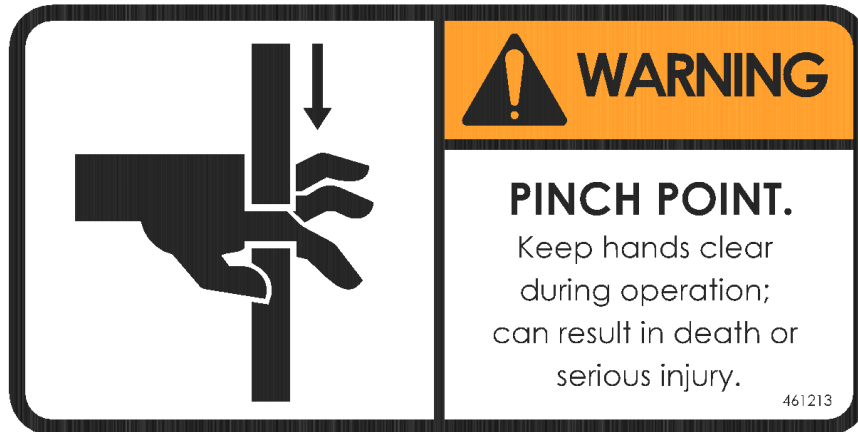

461213

PINCH POINT - WARNING

- Keep extremities clear of equipment. Object(s) can move or shift; can result in death or serious injury.
- Hazards may include, but are not limited to, hinge mechanism movement, pin movement, row unit movement and shifting, accessory movement and shifting, etc.

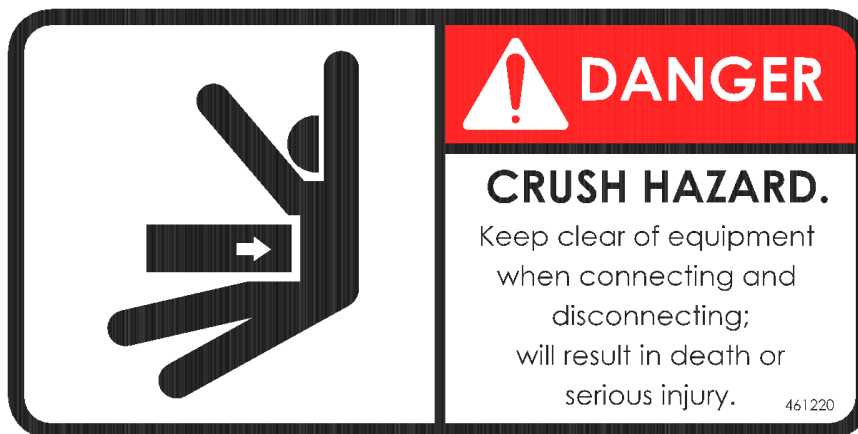

461220

CRUSH HAZARD - WARNING

- Keep clear of moving and shifting equipment. Equipment movement area; will result in death or serious injury.
- Hazards may include, but are not limited to, connection and disconnection of equipment, unexpected equipment shifting, etc.

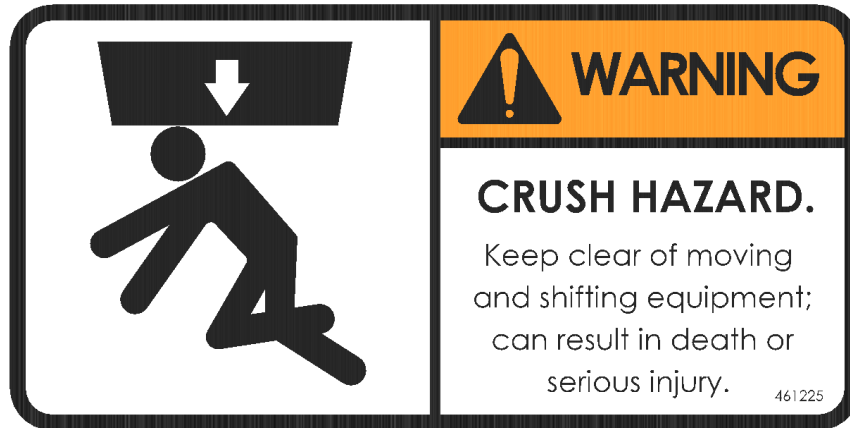

461225

CRUSH HAZARD - WARNING

- Keep clear of moving and shifting equipment. Equipment can move or shift; can result in death or serious injury.
- Hazards may include, but are not limited to, folding wing movement, raised equipment movement and shifting, etc.



461230

NO RIDERS - WARNING

- Never allow riders on equipment; can result in death or serious injury.
- Hazards may include, but are not limited to, falling from equipment, falling into equipment, injury while on equipment, etc.



461248

CONTENTS UNDER PRESSURE - WARNING

- Do not operate if damaged or improperly pressurized. Damaged or improperly pressurized components can discharge; can result in death or serious injury.
- Hazards may include, but are not limited to, damaged tire and/or rim, over pressurized tire, excessive tire wear, tire tears or punctures, ect.



461250

HIGH PRESSURE FLUID - DANGER

- Use safe practices. Fluid injection can occur; will result in death or serious injury.
- Hazards may include, but are not limited to, injury beyond the entry point, over pressurized components, damaged components, components with excessive wear, swollen components, ect.

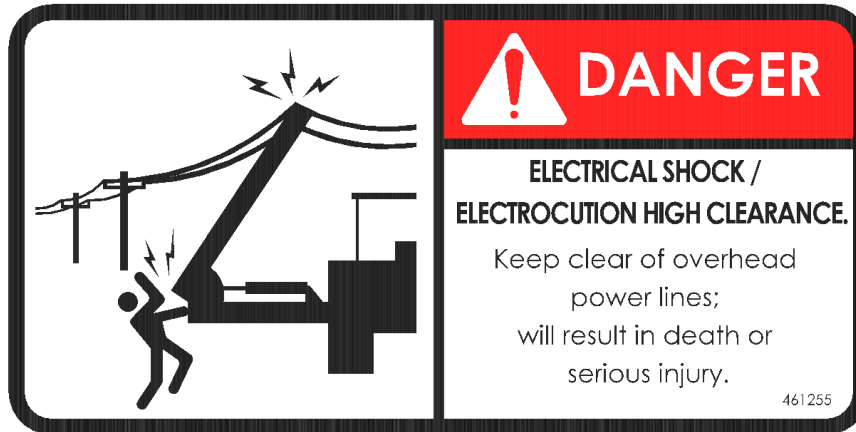

461255

ELECTRICAL SHOCK/ELECTROCUTION HIGH-CLEARANCE DANGER

- Keep clear of overhead power lines, maintain 20-foot minimum distance. Electrical shock and/or electrocution can occur; will result in death or serious injury.
- Hazards may include, but are not limited to, high clearance equipment, low clearance power lines, lack of awareness of surroundings, etc.

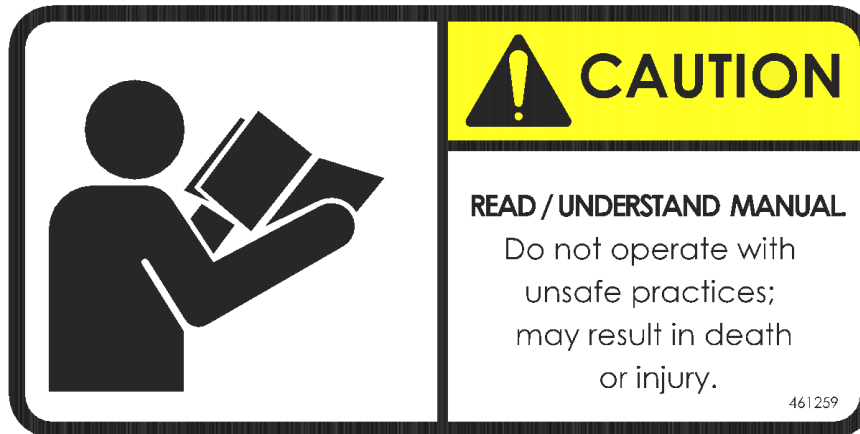

461259

READ/UNDERSTAND MANUAL - CAUTION

- Do not operate without a complete understanding of the owner's manual. Do not operate with unsafe practices; may result in death or injury.
- Hazards may include, but are not limited to, compromising the safety of yourself and/or others, lack of awareness, damage to equipment, etc.



SAFETY SIGN CARE

- Keep safety signs clean and legible at all times.
- Replace safety signs that are missing or have become illegible.
- Replaced parts that displayed a safety sign should also display the current sign.
- Safety signs are available from Hawkins Ag.

HOW TO INSTALL SAFETY SIGNS

- Be sure that the installation area is clean and dry.
- Decide on the exact position before you remove the backing paper.
- Remove the smallest portion of the split backing paper.
- Align the decal over the specified area and carefully press the small portion with the exposed stick backing in place.
- Slowly peel back the remaining paper and carefully smooth the remaining portion of the decal in place.
- Small air pockets can be pierced with a pin and smoothed out using the piece of decal backing paper.

REMEMBER: If Safety Signs have been damaged, removed, become illegible or parts replaced without decals, new decals must be applied. New decals are available from Hawkins Ag.

**Hawkins Ag
2120 4th Ave
Holdrege, NE 68949**

**308.708.8185
www.hawkinsag.com**

PREPARATION & SET-UP



This section helps you prepare your tractor and StripCat™ for use. You must level the implement, hook up the implement hydraulics to the tractor, and check that the hydraulics have been bled.

POST-DELIVERY/SEASONAL SET-UP

On initial delivery, use with a new tractor, and seasonally check and as necessary, complete these items before continuing to the routine set-up items:

- Bleed hydraulic fold system (page 54)
- Check/Change Hitch Configuration
- Hitching Tractor to Implement
- Hydraulic Hose Hook-up
- Light Kit Guide and Relocation
- Electrical Hook-up
- Leveling the Implement

PRE-TILLAGE SET-UP

Complete this checklist before routine set-up:

- Read and understand important "Safety" information starting on page 3.
- Check that all working parts are moving freely, bolts are tight, and cotter pins are spread.
- Check that all grease fittings are in place and lubricated. See "Maintenance & Lube" on page 53.
- Check that all safety decals and reflectors are correctly located and legible. Replace if damaged. See "Safety Sign Locations" starting on page 5.

PREPARATION & SET-UP



CHECK/CHANGE HITCH CONFIGURATION

On initial delivery, use with a new tractor, and seasonally check and as necessary, complete these items before continuing to the routine set-up items:

Choose a hitch option that is compatible with your tractor 3-point. The StripCat™ has two hitch configurations:

- Category 3
- Category 4

Changing between hitch categories requires removing pins at the implement hitch.

TO OPERATE AS CATEGORY 3

1. Remove and store the Category 4 pins.

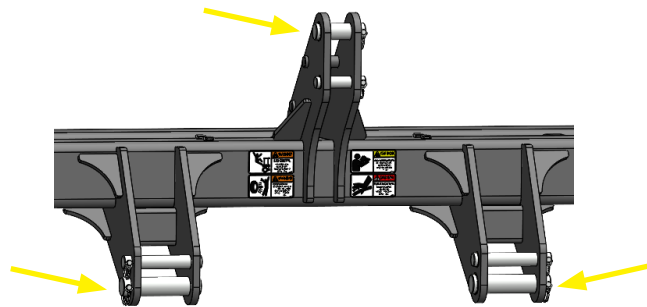

2. Once removed, the remaining pins are set to run the implement with a Category 3 hitch.

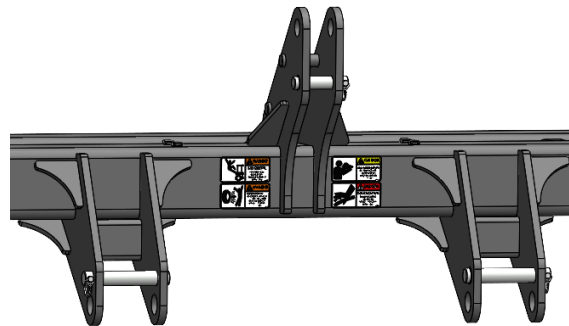

****SEE NEXT PAGE FOR CATEGORY 4 HITCH SET-UP****

PREPARATION & SET-UP



TO OPERATE AS CATEGORY 4

1. Remove and store the Category 3 pins.

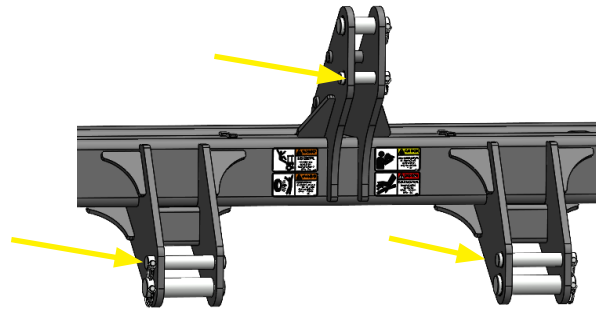

2. Once removed, the remaining pins are set to run the implement with a Category 4 hitch.

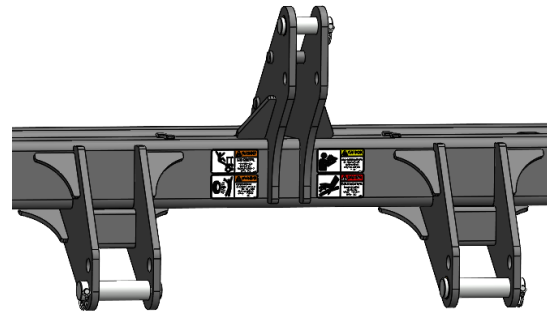



HITCHING TRACTOR TO IMPLEMENT

On initial delivery, use with a new tractor, and seasonally check and as necessary, complete these items before continuing to the routine set-up items:

1. Connect the tractor 3-point lift arms to the lower hitch pins. If using a quick hitch, ensure that the pins lock securely.
2. Connect the top link to the upper hitch pin. Front-to-back leveling is performed in later steps.

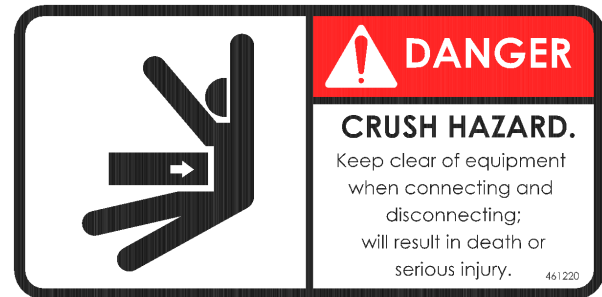

461220

CRUSH HAZARD - WARNING

- Keep clear of moving and shifting equipment. Equipment movement area; will result in death or serious injury.
- Hazards may include, but are not limited to, connection and disconnection of equipment, unexpected equipment shifting, etc.

PREPARATION & SET-UP



HYDRAULIC HOSE HOOK-UP

The StripCat™ is equipped with independently controlled fold cylinders to individually fold the left and right wings.

This requires the use of two remote valves. Hoses at base end of cylinder will unfold machine. Rod end hoses will fold machine up.

1. Connect fold hoses for left wing into remote valve of choice.
2. Connect fold hoses for right wing into remote valve of choice.
3. If your machine is equipped with hydraulic tripping function, connect hoses from tripping manifold to remote valve of choice.
4. Check and make sure all hoses are tied up and secure before use.



461250

HIGH PRESSURE FLUID - DANGER

- Use safe practices. Fluid injection can occur; will result in death or serious injury.
- Hazards may include, but are not limited to, injury beyond the entry point, over pressurized components, damaged components, components with excessive wear, swollen components, ect.



LIGHT KIT GUIDE AND RELOCATION

The light kit is installed at the factory. However, due to shipping requirements and other circumstances, some positions are altered and SMV sign or lights may need relocated before use. Typically, the SMV sign is the only component that needs relocated; please check all components. Check that all forward-facing reflectors and lights are visible from the front and all rear-facing reflectors and lights are visible from the rear. Please refer to the depiction below for component locations.

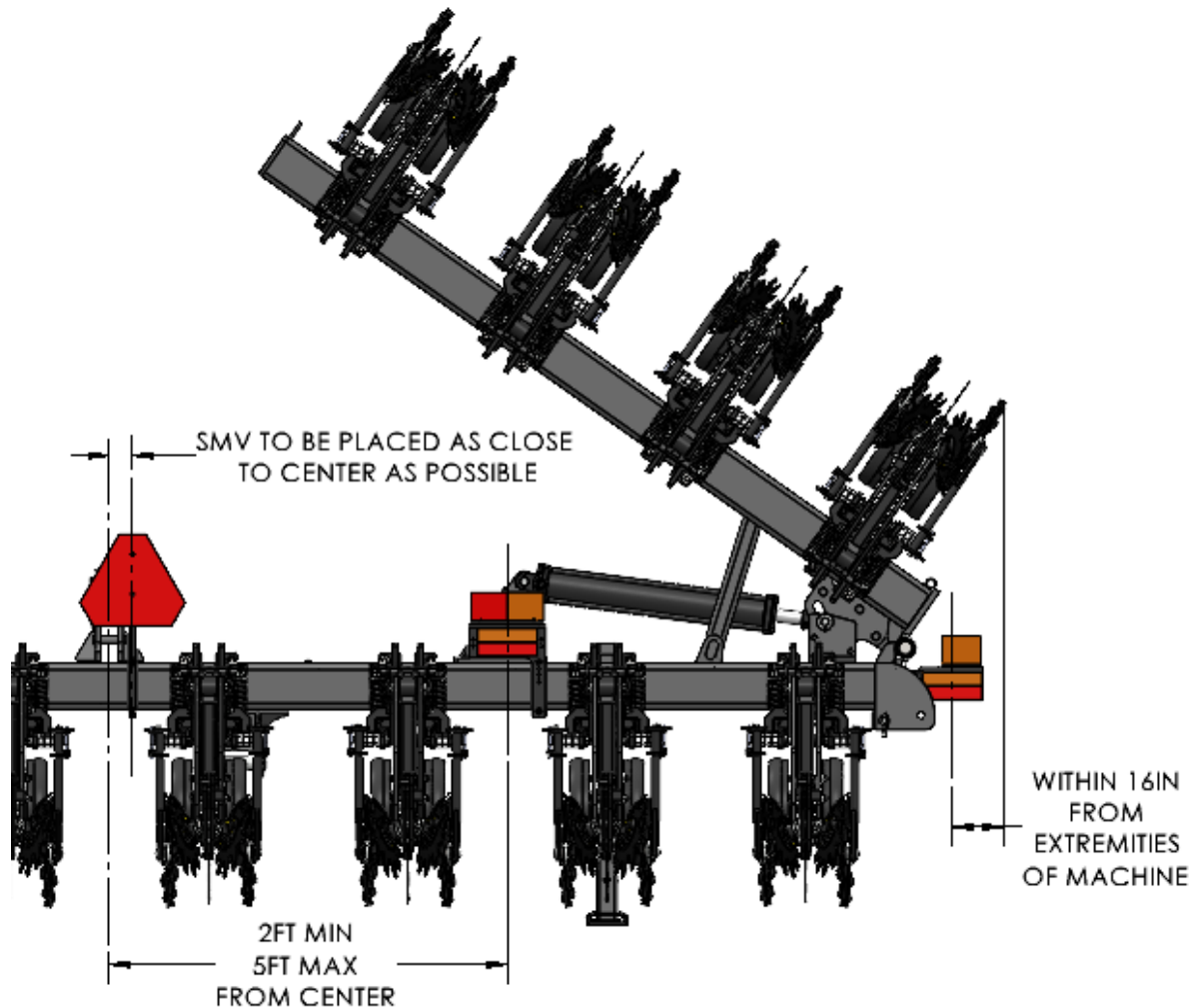



ELECTRICAL HOOK-UP

Lights are connected using a standard 7-pin connector. To connect, simply lift receptacle cover, align plug and insert. To disconnect, lift receptacle cover and remove plug. Once connected, check to make sure all lights are working properly. If lights are not working properly, contact your dealer to fix before transporting on public roadways.

7-pin Connector





LEVELING THE IMPLEMENT

Center Frame L/R Leveling (Figure 1)

1. Hitch the StripCat™ to a tractor (page 14).
2. Raise the implement.
3. Adjust the tractor 2-point lift arms so that the center section tool bar is level.

Figure 1

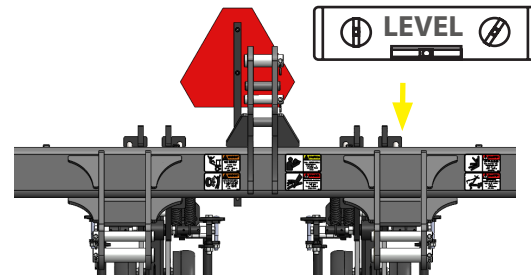

Wing Leveling (Figure 2 & 3)

1. Remove wing lock pins from the lock position, and place in the non-locking position before folding the wings.
2. Check wing for level at the top of the tool bar.
3. Fold implement to access leveling bolts.
4. If wing is too high, tighten bolts in 1/4-1/2" turn increments, unfolding machine to re-check level. If wing is too low, loosen bolts in 1/4-1/2" turn increments, unfolding machine to re-check level.
5. Repeat process until wing is level.

Figure 2

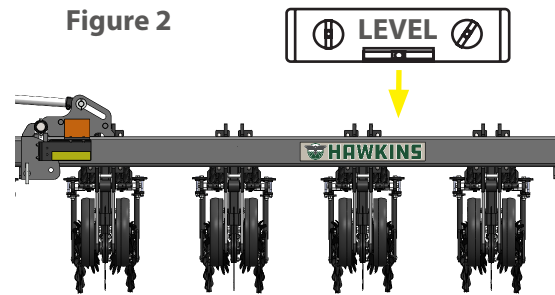
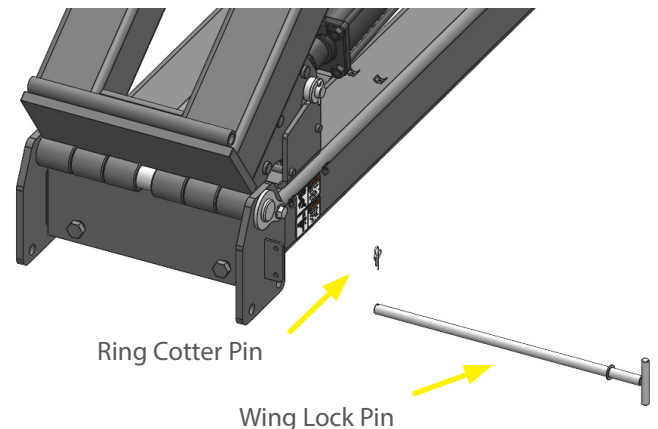

Figure 3



Front-to-Back Leveling

See "Leveling the Machine" on page 25. This adjustment needs to be completed in field conditions.



CRUSH HAZARD - WARNING

- Keep clear of moving and shifting equipment. Equipment can move or shift; can result in death or serious injury.
- Hazards may include, but are not limited to, folding wing movement, raised equipment movement and shifting, etc.



REMEMBER

Your best assurance against accidents is a careful and responsible operator. If there is any portion of this manual or function you do not understand, contact Hawkins Ag.



BEFORE OPERATION

- Carefully study and understand this manual.
- Do not wear loose-fitting clothing which may catch in moving parts.
- Always wear protective clothing and substantial shoes.
- It is recommended that suitable eye protection be worn.
- The operator may come in contact with certain materials which may require specific safety equipment (ie: extremely dusty, molds, fungus, bulk fertilizers).
- Keep bolts tightened to specific torque listed on **Bolt Torque Chart**.
- Give the unit a visual inspection for any loose bolts, worn parts or cracked welds, and make necessary repairs. Follow the maintenance safety instructions included in this manual.
- Be sure that there are no tools lying on or near the equipment.
- Do not use the unit until you are sure that the area is clear, especially children and animals.
- Because it is possible that this equipment may be used in dry areas or in the presence of combustibles, special precautions should be taken to prevent fires and fire fighting equipment should be readily available.
- Don't hurry the learning process or take the unit for granted. Ease into it and become familiar with your new equipment.
- Practice operation of your equipment and its attachments. Completely familiarize yourself and other operators with its operation before using.



DURING OPERATION

- Keep hands, feet, and clothing clear of moving parts.
- Do not clean, lubricate or adjust your equipment while it is moving.
- Be especially observant of the operating area and terrain - watch for holes, rocks or other hidden hazards. Always inspect the area prior to operation.
- Periodically clear the equipment of brush, twigs or other materials to prevent buildup of dry combustible materials.
- Do not walk or work under raised components or attachments unless securely positioned and blocked.
- Keep all bystanders, pets and livestock clear of the work area.
- Never stand alongside of unit with engine running or attempt to start engine and/or operate machine while standing alongside of unit.
- As a precaution, always recheck the hardware on equipment following every 100 hours of operation. Correct all problems. Follow the maintenance safety procedures.



This section covers general operating procedures. Experience, machine familiarity, and the following information will lead to efficient operation and good working habits. Always operate farm machinery with safety in mind.

PRE-START CHECKLIST

Perform the following steps before transporting the StripCat™ to the field.

- Carefully read "Important Safety Information" on page 3.
- Lubricate implement as indicated under "Maintenance & Lube" on page 53.
- Check all tires for proper inflation.
- Check all bolts, pins, and fasteners. Torque as shown in "Bolt Torque Chart" on page 55.
- Check implement for worn or damaged parts. Repair or replace parts before going to the field.
- Check hydraulic hoses, fittings, and cylinders for leaks. Repair or replace before going to the field.
- Perform all beginning-of-season and daily service items under "Maintenance & Lube" on page 53.



WING LOCK PINS

Remove the wing lock pins from the lock position and place in the non-locking position before folding the wing(s). To move wing lock pin position, pull ring cotter pin. Then, pull the pin out of the toolbar and reinsert it into the desired position. Insert the ring cotter pin.

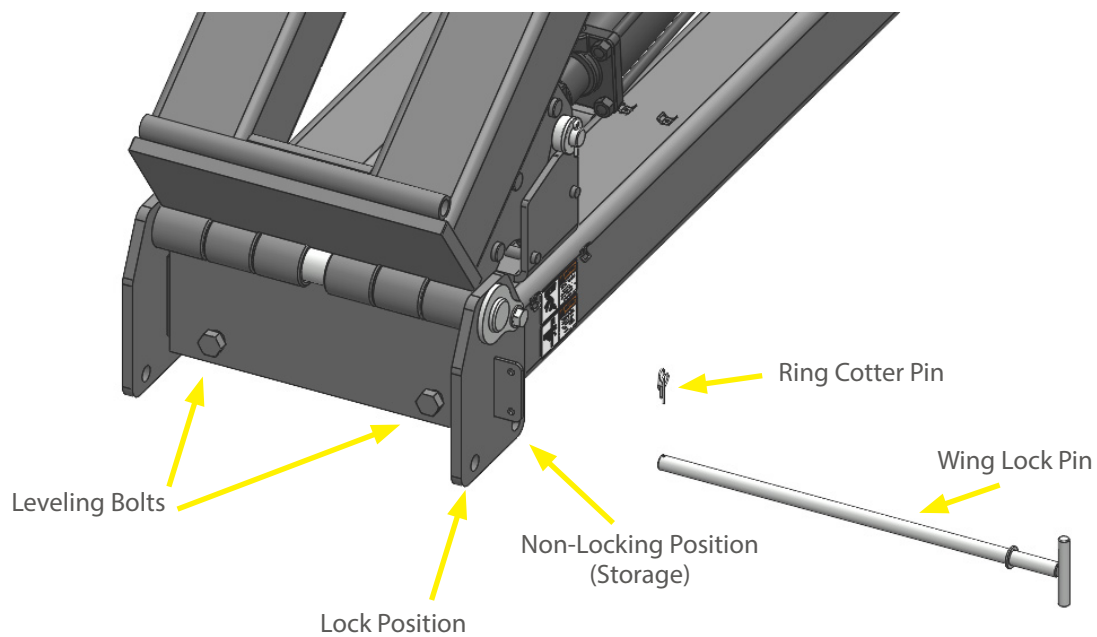



FOLDING

Fold the implement for movements on public roads and between fields and narrow clearances. Do not use the folded configuration for parking or storage.

1. Hitch tractor (page 14).
2. Move to level ground. Be aware of vertical clearance needed to fold implement.
3. Put tractor in Park with parking brake engaged.
4. Verify that the wing lock pins are not installed in the lower lock holes (page 21).
5. Clear all persons from on or near the implement.
6. Use the tractor 3-point hitch to raise the implement slightly (so that the row units are off the ground).
7. Slowly move fold circuit lever(s) to retract cylinders. Observe the fold operation.
8. Wait for both wings to reach the fully folded position. Set tractor remote(s) to Neutral to hold at folded.

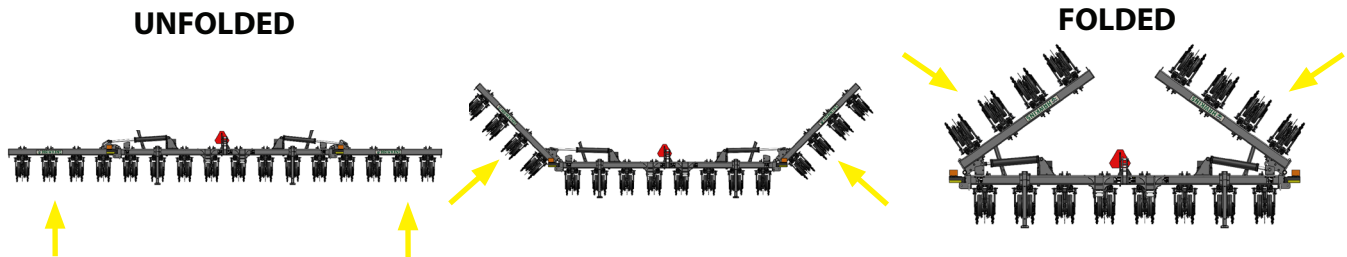

TIP OVER/CRUSHING HAZARD AND EQUIPMENT DAMAGE RISK:
Never unhitch a folded implement. A folded implement could topple backward or forward, causing serious injury or death and certain severe equipment damage. When unhitched, the implement is supported at the rear only by row unit tools and spring tension. Slopes, soft soils, and soils later softened by rain are particularly dangerous.



ELECTRICAL SHOCK/ELECTROCUTION HIGH-CLEARANCE DANGER:
Keep clear of overhead power lines, maintain 20-foot minimum distance. Electrical shock and/or electrocution can occur; will result in death or serious injury. Hazards may include, but are not limited to, high clearance equipment, low clearance power lines, lack of awareness of surroundings, etc.



CRUSH HAZARD - WARNING:
Keep clear of moving and shifting equipment. Equipment can move or shift; can result in death or serious injury. Hazards may include, but are not limited to, folding wing movement, raised equipment movement and shifting, etc.



UNFOLDING

Unfold the implement for adjustments, field operations, maintenance, parking and storage.

1. Unless the implement was folded, with the currently hitched tractor, only a short time ago, check for evidence of oil leaks. Check the ground at hitch connections, hose fittings and under cylinders.
2. Be aware of vertical and horizontal clearances needed to unfold the implement.
3. Put tractor in Park with parking brake engaged.
4. Verify that the wing lock pins are not installed in the lower lock holes (page 21).
5. Clear all persons from on or near the implement.
6. Use the tractor 3-point hitch to raise the implement slightly (so that the row units are off the ground).
7. Slowly move fold circuit lever(s) to Extend cylinders. Observe the unfold operation.
8. Wait for both wings to reach the fully unfolded position. Set tractor remote(s) to Neutral to lock at unfolded.

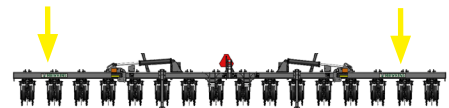
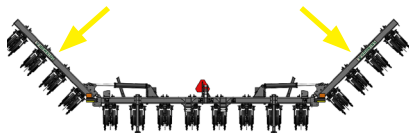
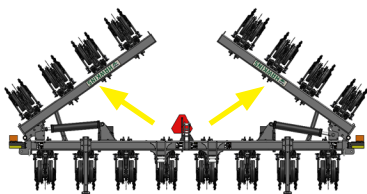

TIP OVER/CRUSHING HAZARD AND EQUIPMENT DAMAGE RISK:

Never unhitch, park, or store a partially folded implement. A partially folded implement could topple backward or forward immediately or at a later time, causing serious injury or death and certain severe equipment damage. When unhitched, the implement is supported at the rear only by row unit tools and spring tension. Slopes, soft soils, and soils later softened by rain are particularly dangerous.



ELECTRICAL SHOCK/ELECTROCUTION - HIGH-CLEARANCE DANGER:

Keep clear of overhead power lines, maintain 20-foot minimum distance. Electrical shock and/or electrocution can occur; will result in death or serious injury. Hazards may include, but are not limited to, high clearance equipment, low clearance power lines, lack of awareness of surroundings, etc.



EQUIPMENT DAMAGE RISK:

Do not leave a partially folded implement lifted for extended periods of time. This places a needless unbalance load on the tractor's lower lift arms.



CRUSH HAZARD - WARNING

Keep clear of moving and shifting equipment. Equipment can move or shift; can result in death or serious injury. Hazards may include, but are not limited to, folding wing movement, raised equipment movement and shifting, etc.



TRANSPORT CHECKLIST

Before transporting the implement, check the following items.

- Transport only with a tractor of proper size and adequate ballast.
- Hitch implement securely to tractor. See “Hitching Tractor to Implement” on page 14.
- Plug implement safety lights into tractor seven-pin connector.
- Make sure implement is folded properly. See “Folding” on page 22. Raise the implement for adequate ground clearance.
- Comply with all national, regional, and local safety laws when traveling on public roads.
- Travel with caution.



DANGER

LOSS OF CONTROL HAZARD:

Ensure that the towing vehicle is adequate for the task. Using an inadequate tow vehicle is extremely unsafe, and can result in loss of control, serious injury and death. To reduce the hazard, use only a 3-point towing vehicle that is both rated for the implement load, and properly ballasted for the load.



DANGER

ELECTRICAL SHOCK/ELECTROCUTION HIGH-CLEARANCE DANGER:

Keep clear of overhead power lines, maintain 20-foot minimum distance. Electrical shock and/or electrocution can occur; will result in death or serious injury. Hazards may include, but are not limited to, high clearance equipment, low clearance power lines, lack of awareness of surroundings, etc.



CAUTION

BRAKING AND LOSS OF CONTROL HAZARD:

Do not exceed 20 mph (32km/h) when driving straight. Do not exceed 13 mph (21 km/h) in turns. The weight of the implement can cause under-steer, and the height of the implement is a tipping hazard.



LEVELING THE MACHINE

When initially setting the StripCat™ up to operate in the field the machine should be set level front to back and level left to right. To level center and wings refer to “Leveling the Implement” section on page 18.

In order to set front to back level of machine, pull into field, then lower implement in ground. Go a short distance while leaving the machine in the ground. Stop, put tractor into park. Then, adjust toolbar height so that bottom of the toolbar measures between 23-24” to the ground.

Once toolbar is set to proper operating height, adjust third-link on tractor until toolbar is level.

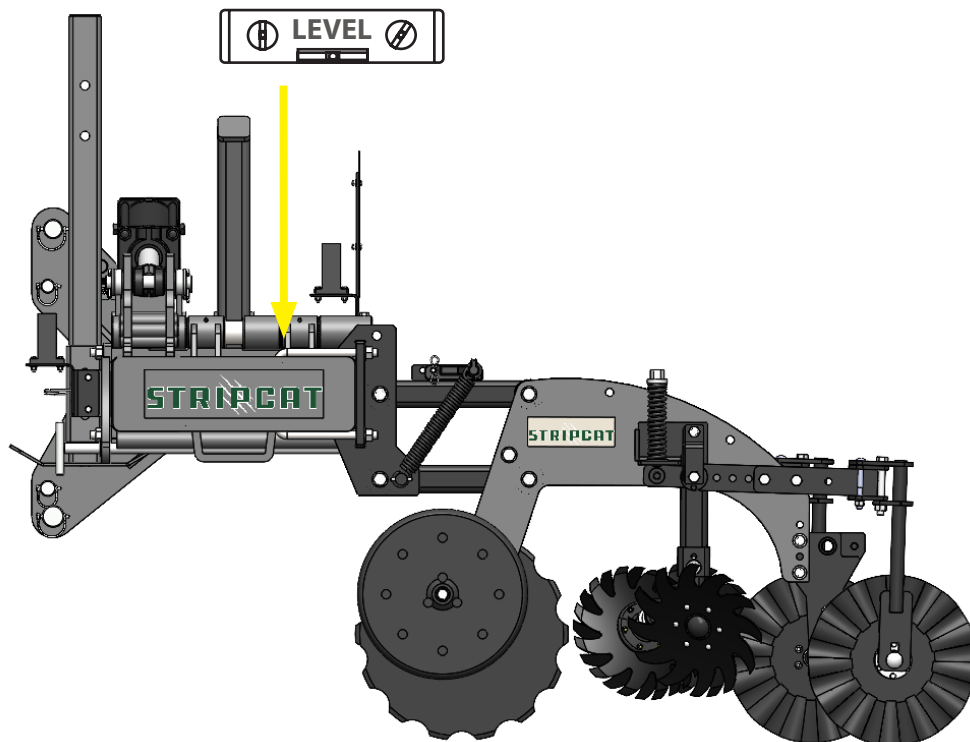



GAUGE WHEEL ADJUSTMENT

Gauge wheels are equipped with two different methods to adjust the depth of the gauge wheels. The first is to use the ratcheting turn buckle. To do this, loosen the jam nut with a combination wrench (1 3/4"). Then, turn the turn buckle to either lengthen or shorten the turn buckle. Then, re-tighten the jam nut.

The second method of adjustment is to change the lower position of the ratcheting turn buckle. The ratcheting turn buckle's standard location is in the center of the 3 holes on the lower arm and is the recommended setting for the StripCat™.

The gauge wheels are designed to help the tractor carry the machine through the field and hold proper depth.

NOTE: Gauge Wheels are optional accessories and do NOT come standard on StripCat™

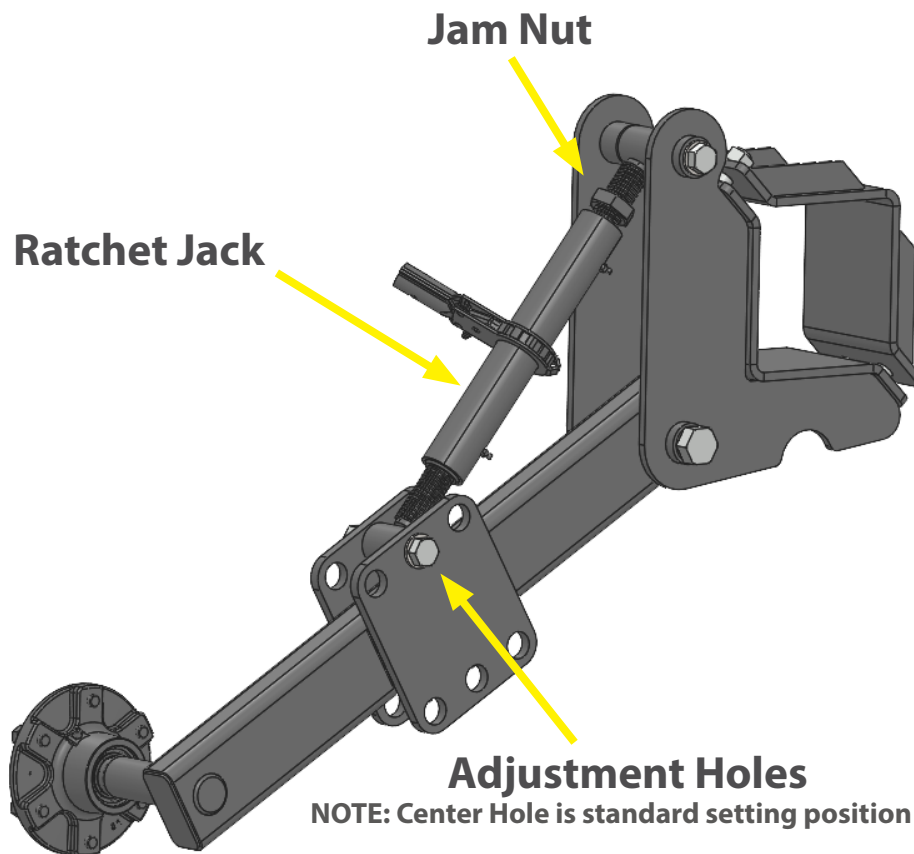



DOWN PRESSURE SPRINGS

The down pressure on each row unit can be adjusted by changing which pin hole the spring retainer is set at:

FRONT HOLE: Lightest down pressure for light or sandy soils

MIDDLE HOLE: Medium down pressure for most soil types.

REAR HOLE: Maximum down pressure for high clay soils, compacted soils, and heavy residue.

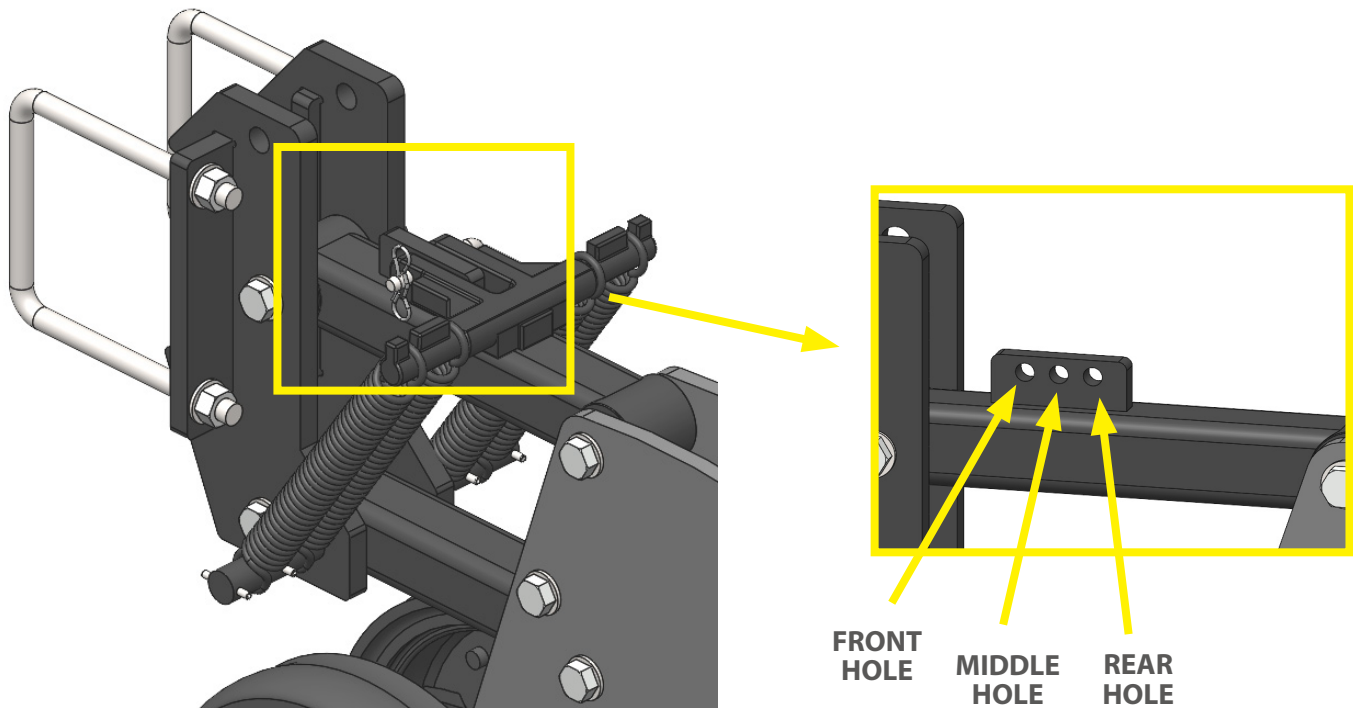

OPERATION



ROW UNIT DEPTH

See pages 29 & 30 for details on how to adjust depth gauge wheel and knife plate settings.

StripCat™ is designed to run the knife at a depth of 5" to 8". Deeper and shallower settings are possible, but not recommended as they will cause excessive knife blowout and/or machine wear.

We make no recommendations for products, placement, or timing of fertilizer applications. Refer to your agronomist for products, placement, depth, and timing for fertilizer application that fit your operation.

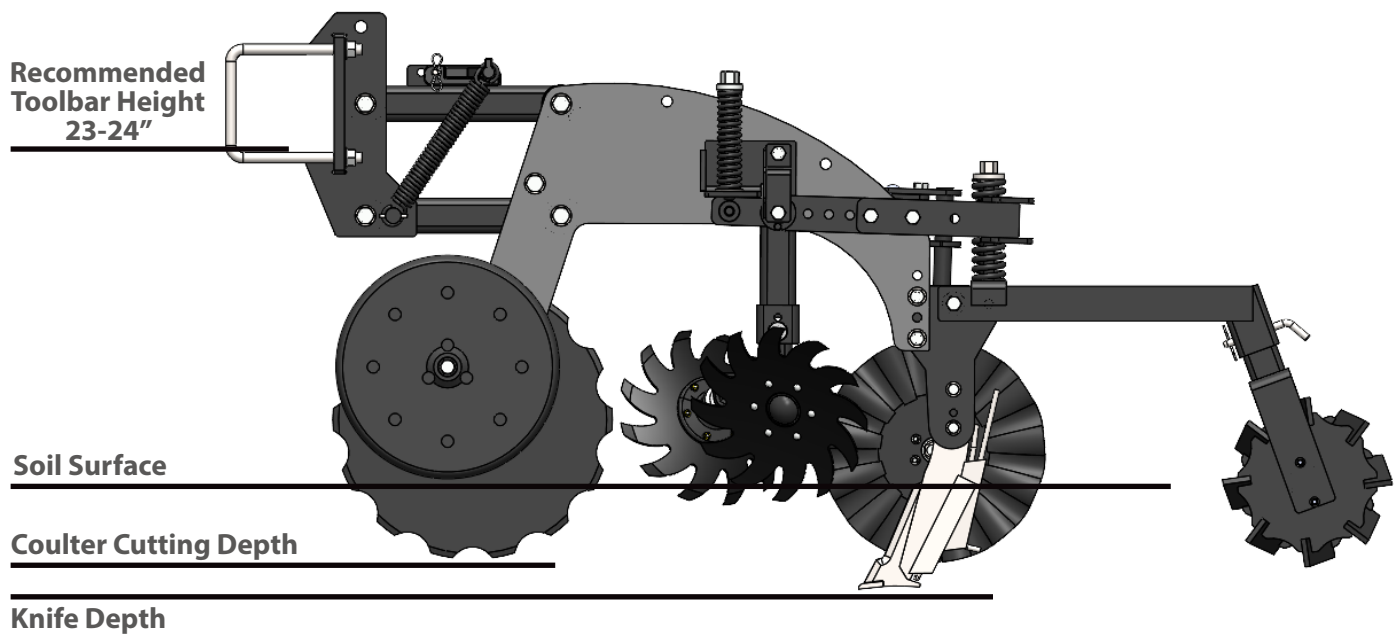

Depth Gauge Wheels Hole Setting	20" Coulters Cutting Depth	Knife Plate Setting	Knife Depth
Top	7.5"	Top Bottom	8" 9.5"
2 nd	6"	Top Bottom	6.5" 8"
3 rd	4.5"	Top Bottom	5" 6.5"
Bottom	3"	Top Bottom	3.5" 5"



ROW UNIT DEPTH ADJUSTMENT

Each row can be adjusted for desired depth by changing the hole position of the depth gauge wheels. The factory setting is the second hole from the top.

To adjust depth, remove the 5/8" bolts from each side using a pair of 15/16" wrenches.

Depth adjustment must be done on each side of the row unit.

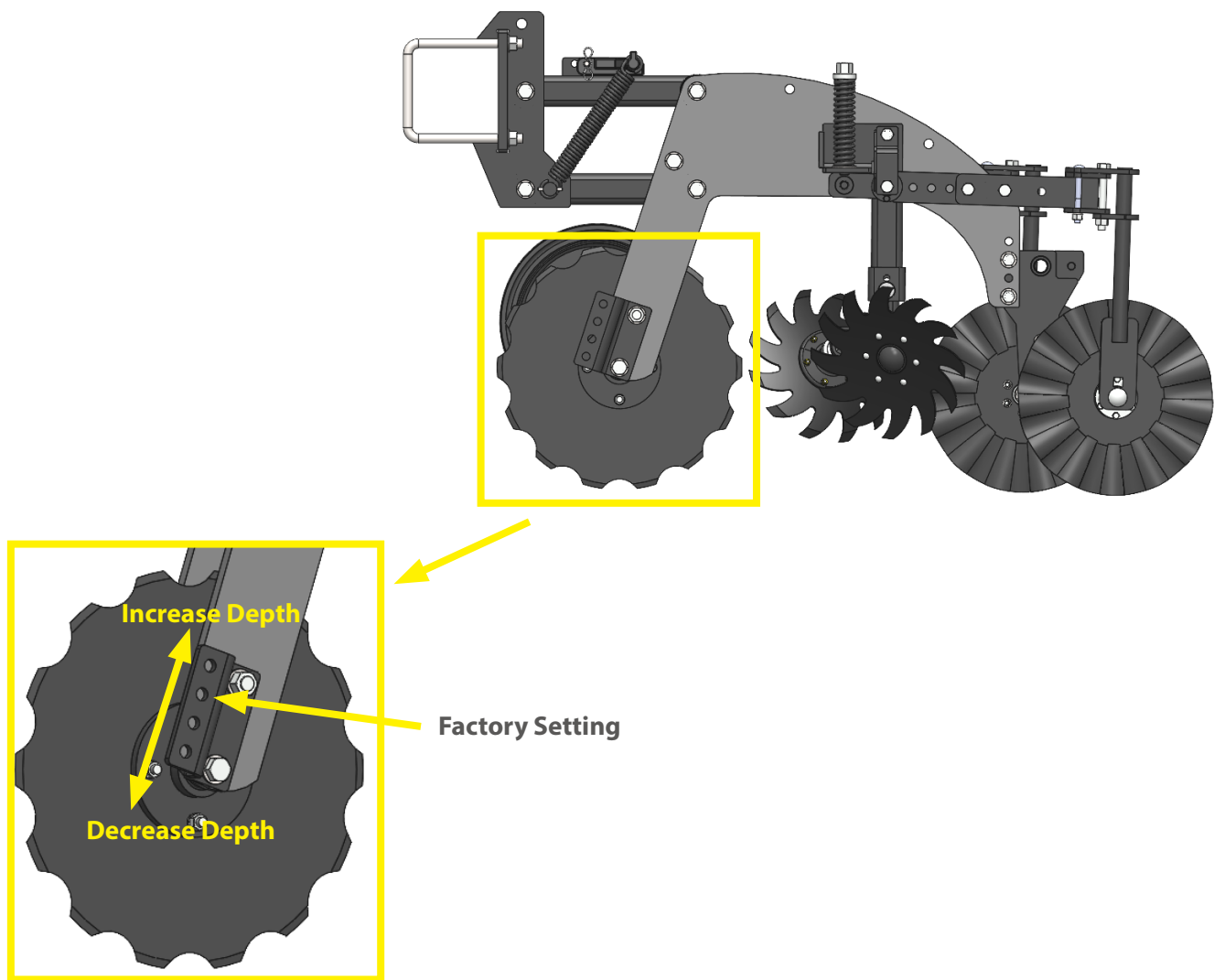



KNIFE PLATE

The knife plate can be set in two different positions with 1-1/2" difference between the two settings.

To change the position of the knife plate, remove the two 5/8" bolts that hold the knife plate between the side plates of the row unit using a pair of 15/16" wrenches. Move the knife plate to the desired position and reinstall and tighten the bolts. Note: You may also have to loosen the bolts that hold the row cleaner tube to allow for free movement of the knife plate within the row unit side plates to complete this process.

The factory setting is the lower set of holes.

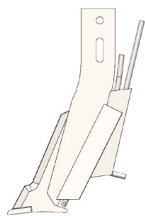
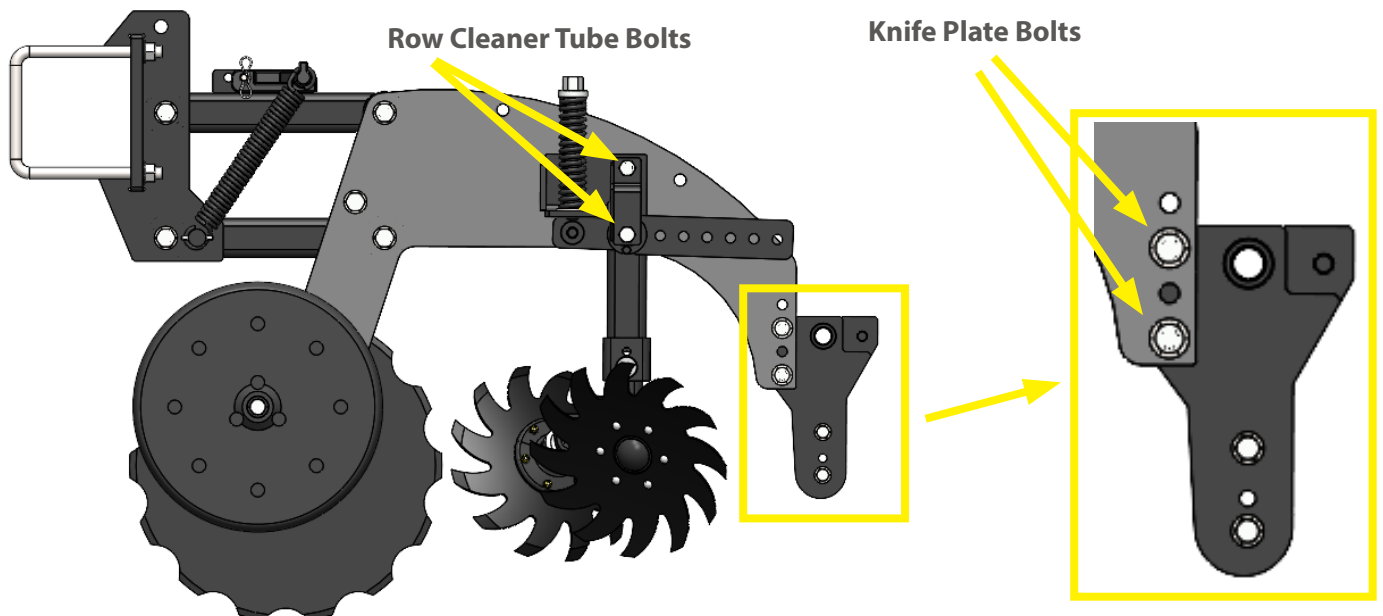

Mini-mole with dual 3/8" tubes
for Liquid and NH3
333890

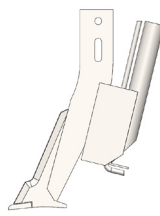

Mini-mole with 1-1/2" Dry Tube
and 3/8" Liquid Tube
333891

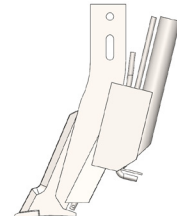

Mini-mole with 1-1/2" Dry Tube
and dual 3/8" Tubes for Liquid and NH3
333892

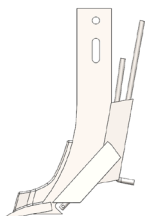

Mole with dual 3/8" tubes
for Liquid and NH3
333895

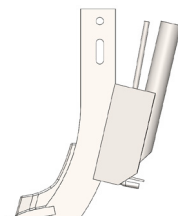

Mole with 1-1/2" Dry Tube
and 3/8" Liquid Tube
333896

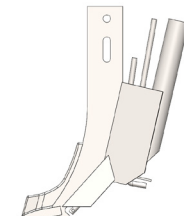

Mole with 1-1/2" Dry Tube
and dual 3/8" Tubes for Liquid and NH3
333897



RESIDUE MANAGER

The residue manager is intended to scratch the surface (1/4"-1/2") to remove most of the residue from the surface without moving too much soil.

The lower the residue manager is set, the more soil will be moved.

To adjust the residue manager, remove the 1/2" retention pin with one hand while supporting the assembly with your other hand, raise or lower the assembly to the desired location, and reinsert the pin in the next available hole.

There are two (2) holes in the residue manager stem allowing for half-step, precise adjustments of the residue managers.

Residue Manager

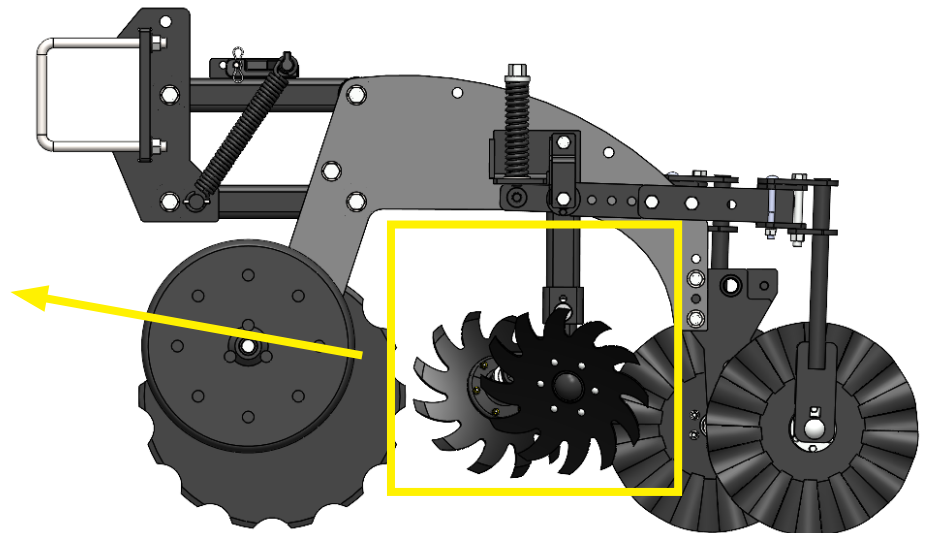
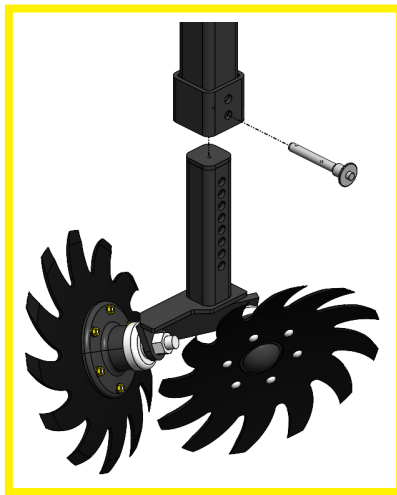

Residue Manager blades are very sharp. Use leather gloves when handling these parts.



ROW CONFIGURATIONS

StripCat™ row units are set up from the factory in left-hand and right-hand configurations based on which side of the residue managers and Independent Berm Builders lead and trail.

Row units are alternated left and right across the machine to allow residue to flow between the units.

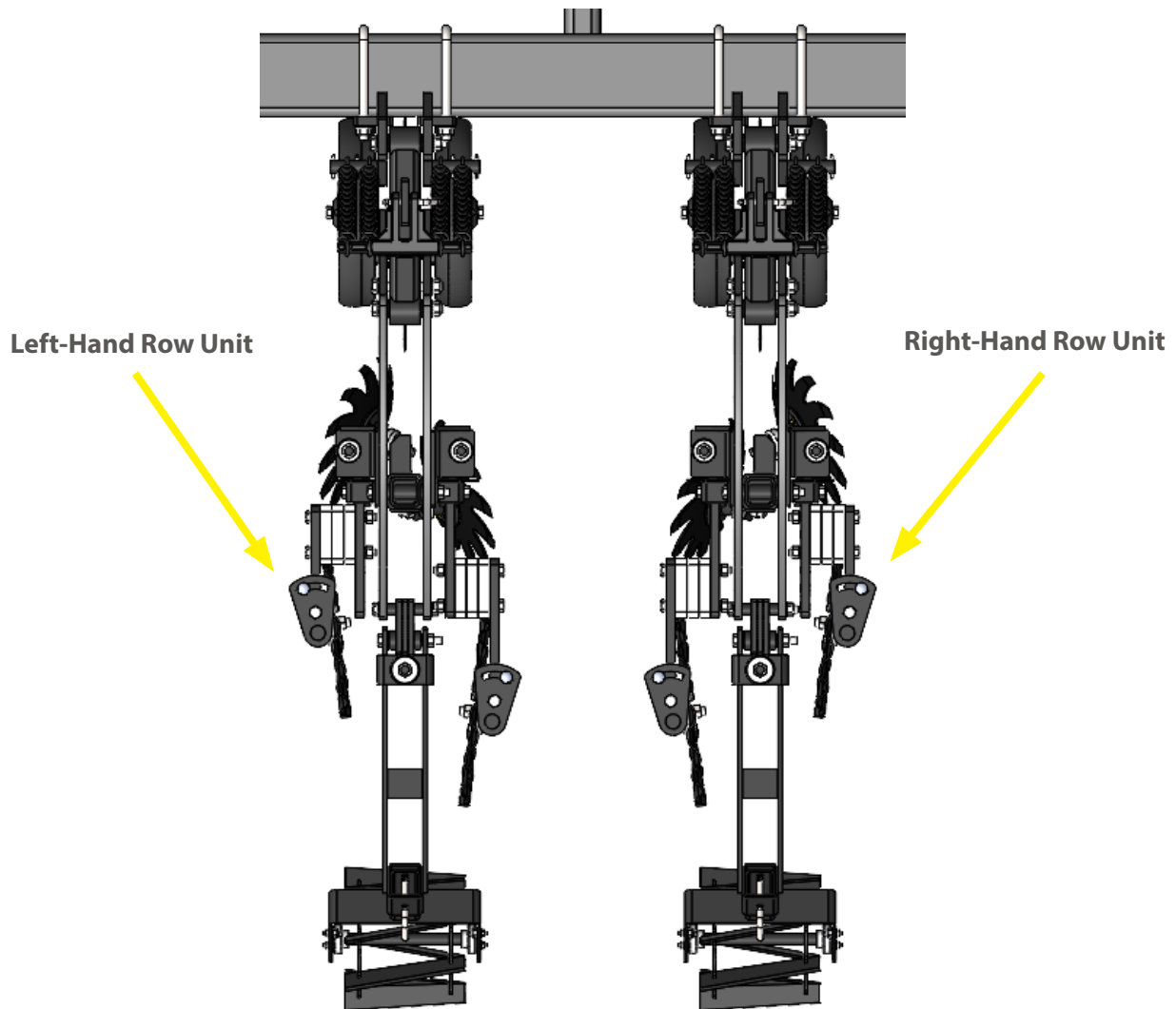



INDEPENDENT BERM BUILDERS

The Independent Berm Builders on StripCat have numerous adjustable features which allow you to customize your strips.

You can adjust down pressure, blade fore/aft, blade toe angle, blade depth, and distance between the blades.

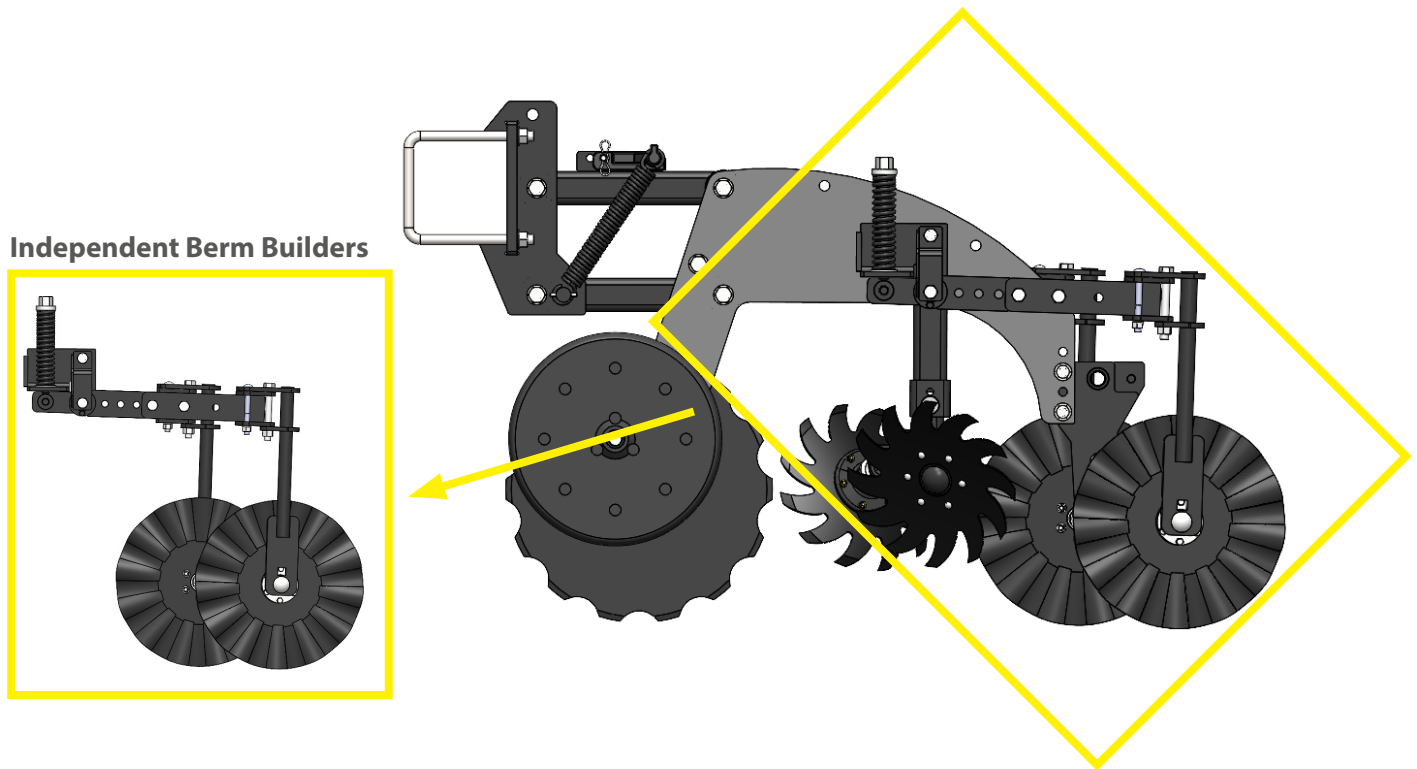



INDEPENDENT BERM BUILDERS - DOWN PRESSURE

Down pressure can be increased or decreased based on conditions. For heavy residue or compacted soil, typically, more down pressure is needed.

To increase down pressure on the berm building discs, tighten the 3/4" nylon lock nut on the IBB arm compression spring. To decrease pressure, loosen nut. This adjustment can be checked by measuring the distance from the spring mount place to the top of the spring cap. The factory setting is approximately 7.25" and can be adjusted from 6" to 7.5"

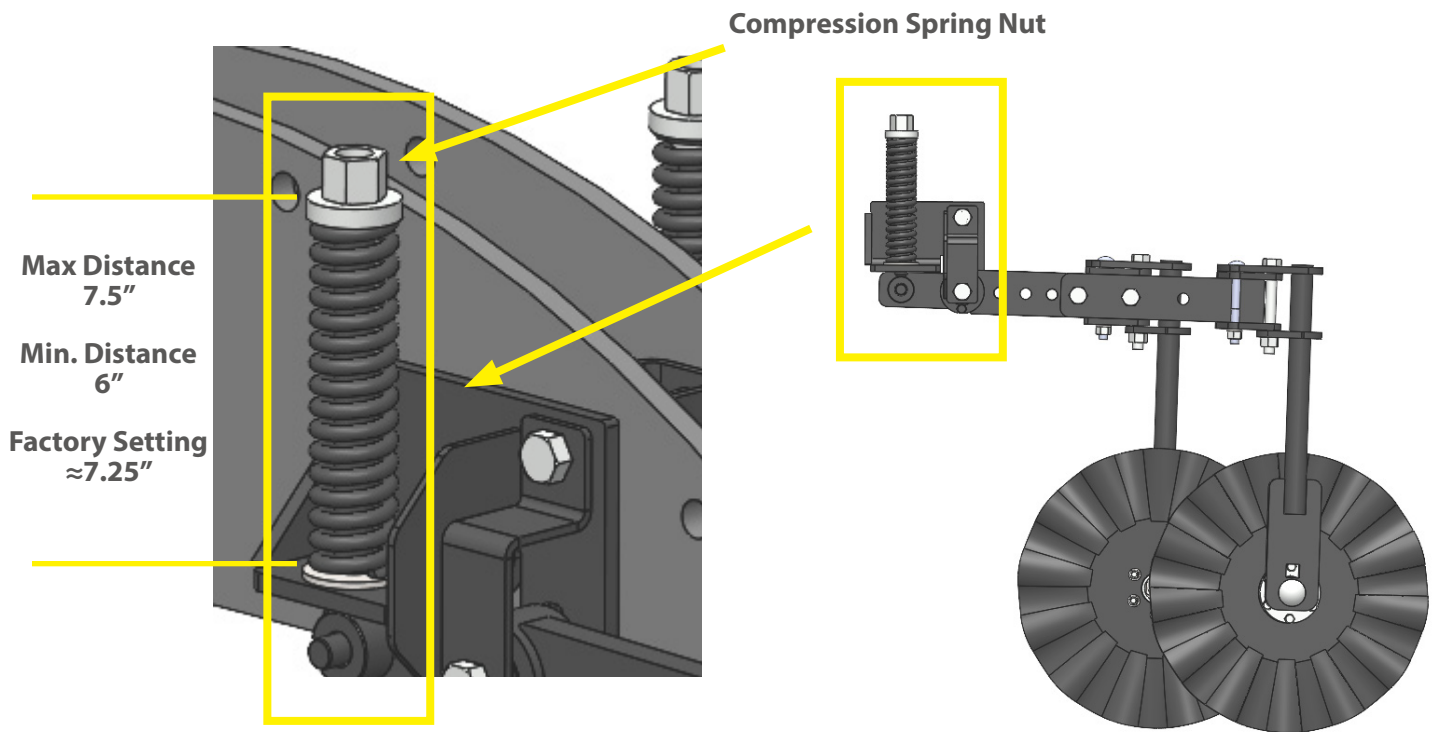



INDEPENDENT BERM BUILDERS - DISC PITCH

Adjusting the pitch of the berm building discs changes the amount of soil being moved into the strip. When the discs are set parallel to the direction of travel, very little soil will be moved. As the pitch of the discs is increased (rear edge of disc moved inward) more soil will be moved into the strip, increasing the size of the berm created by the machine.

To adjust the pitch of the IBBs loosen the carriage bolt on the adjustment plate with a 3/4" wrench (you may also have to loosen the pivot bolt with a pair of 15/16" wrenches) then adjust the angle of the discs to your preference and retighten bolts. In most cases, the left and right discs should be set to the same angle for an even berm.

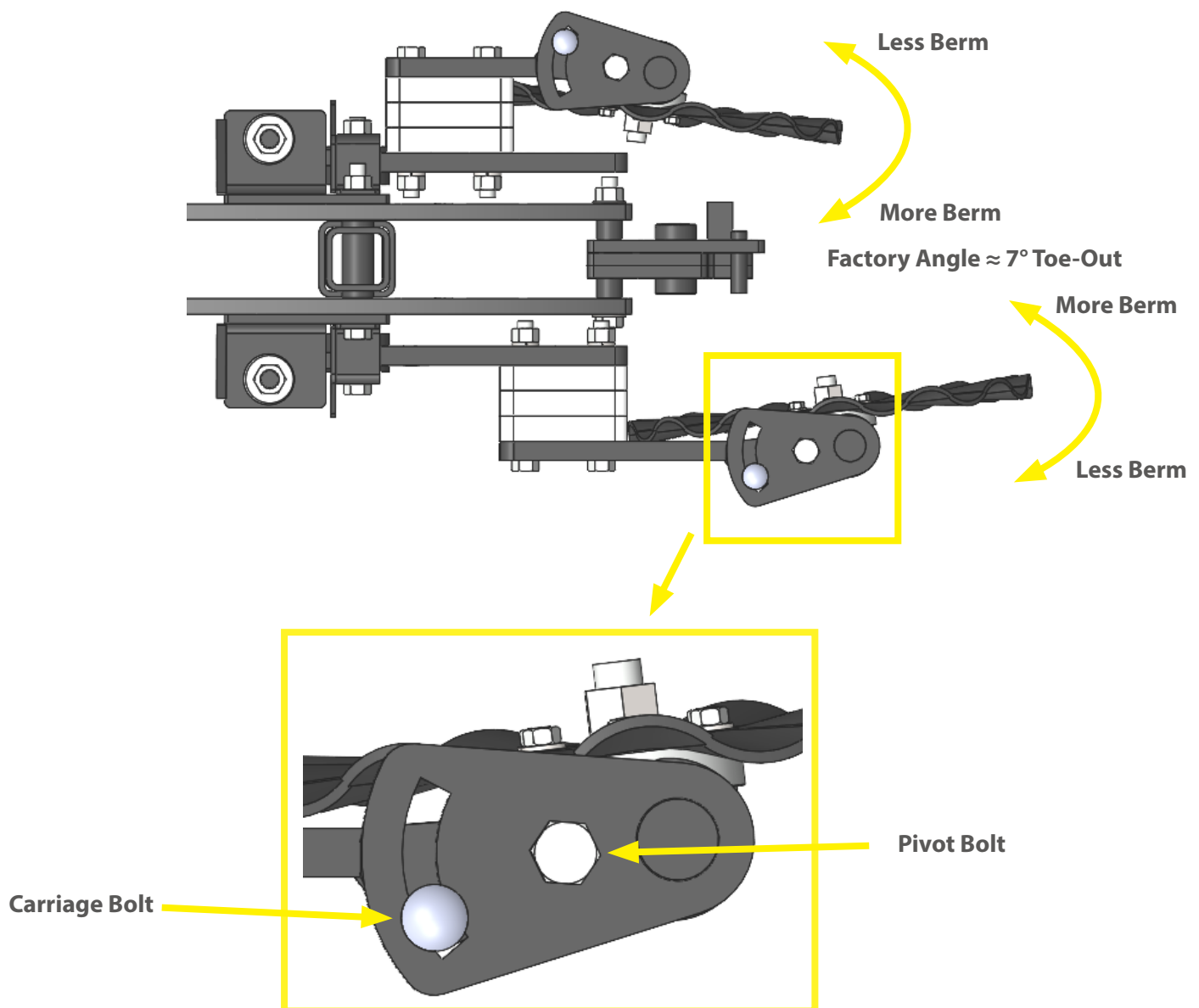



INDEPENDENT BERM BUILDERS - BLADE DEPTH

Depth of the Berm Building Blades can be adjusted by changing which hole the disc hub is bolted into. This adjustment allows for 1-1/4" of difference in blade depth.

To change the depth of the blades use a 1-1/8" socket to remove the 3/4" nut from the carriage bolt, move the bolt to the other hole, making sure to get the same number of washers between the hub and stem plate as before removal, and retighten in the new position.

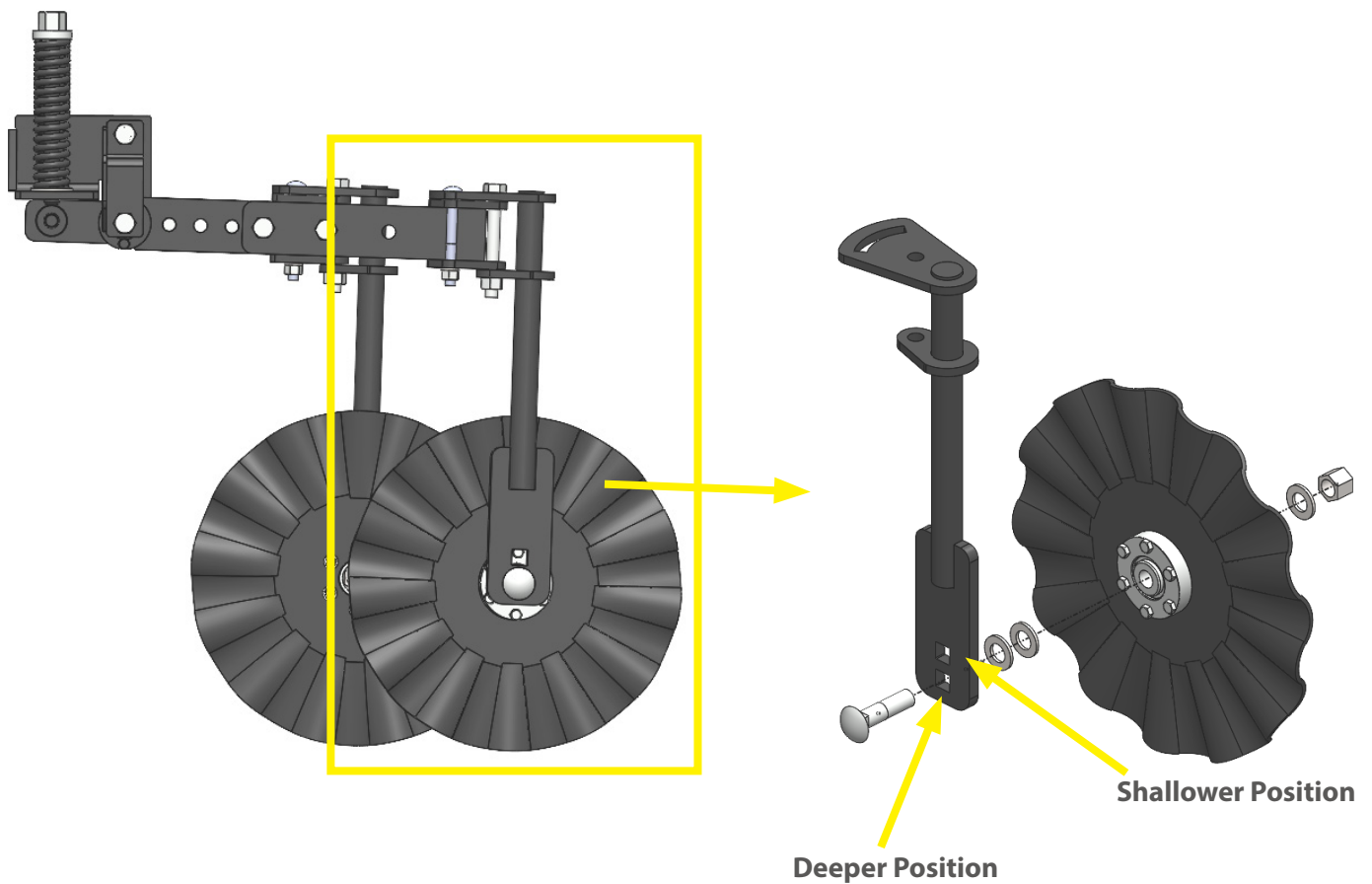



INDEPENDENT BERM BUILDERS - DISC SPACING

Spacing between the Berm Building Discs can be changed to adjust the shape and size of the berm being created by the row unit.

To achieve different spacing of the Berm Building Discs, poly spacer blocks can be removed or added on each side of the row unit. Using a pair of 15/16" wrenches, remove the two 5/8" bolts that hold the rear IBB arms in place and either remove or add the desired number of spacer blocks from each side.

***Note: Put unused spacer blocks on outside of arm to continue to use same length bolts.**

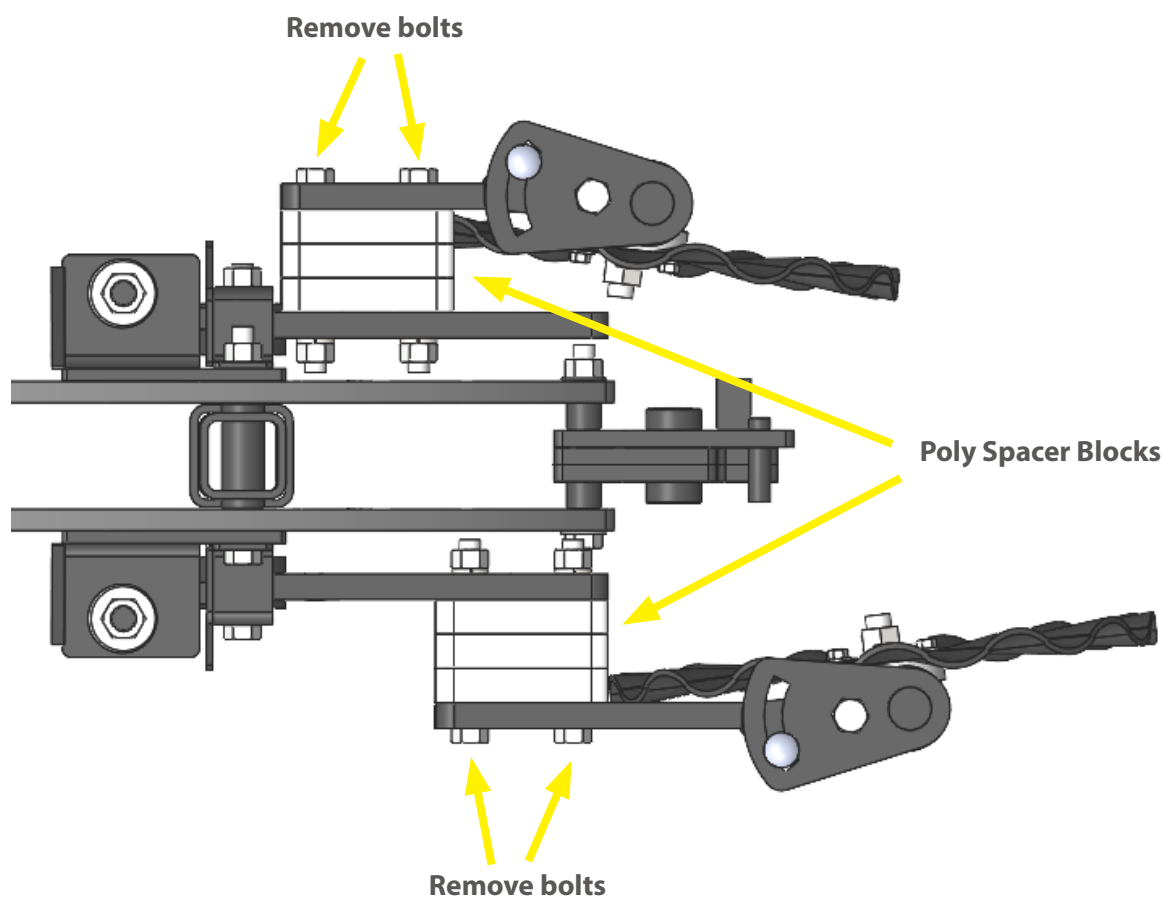

Recommended Number of Poly Spacers	
Row Spacing	Number of Poly Spacers
20"-22"	2 Blocks
30" or farther	3 Blocks



INDEPENDENT BERM BUILDERS - FORE & AFT

The Berm Building Discs can be adjusted fore & aft in order to manage residue flow and blowout from the knife.

To adjust the fore & aft of the Berm Building Discs, remove the two 5/8" bolts that attach the rear IBB arms to the front IBB arm using a pair of 15/16" wrenches. Reinstall in the desired position and tighten bolts.

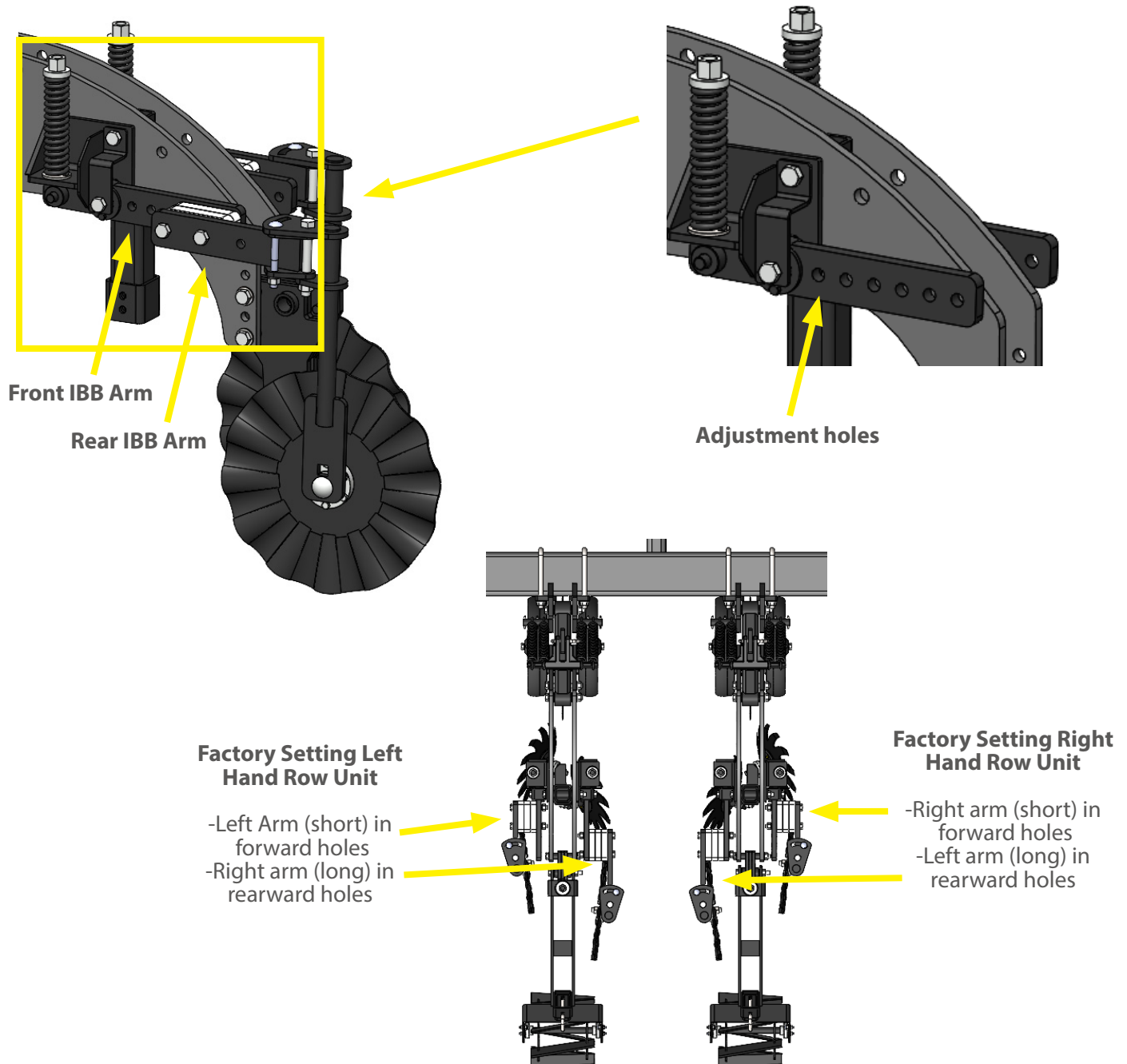



REAR FINISHING TOOLS

StripCat can be outfitted with 3 different rear finishing tools: a rolling basket, iron tires, and rubber packing wheels.

Each rear accessory can be added/removed by removing a 1/2" retaining pin.

Each accessory can be adjusted for height by placing the pin in different holes on the stem of the accessory.

To increase down pressure on the berm building discs, tighten the 3/4" nylon lock nut on the down-pressure spring. To decrease pressure, loosen nut.

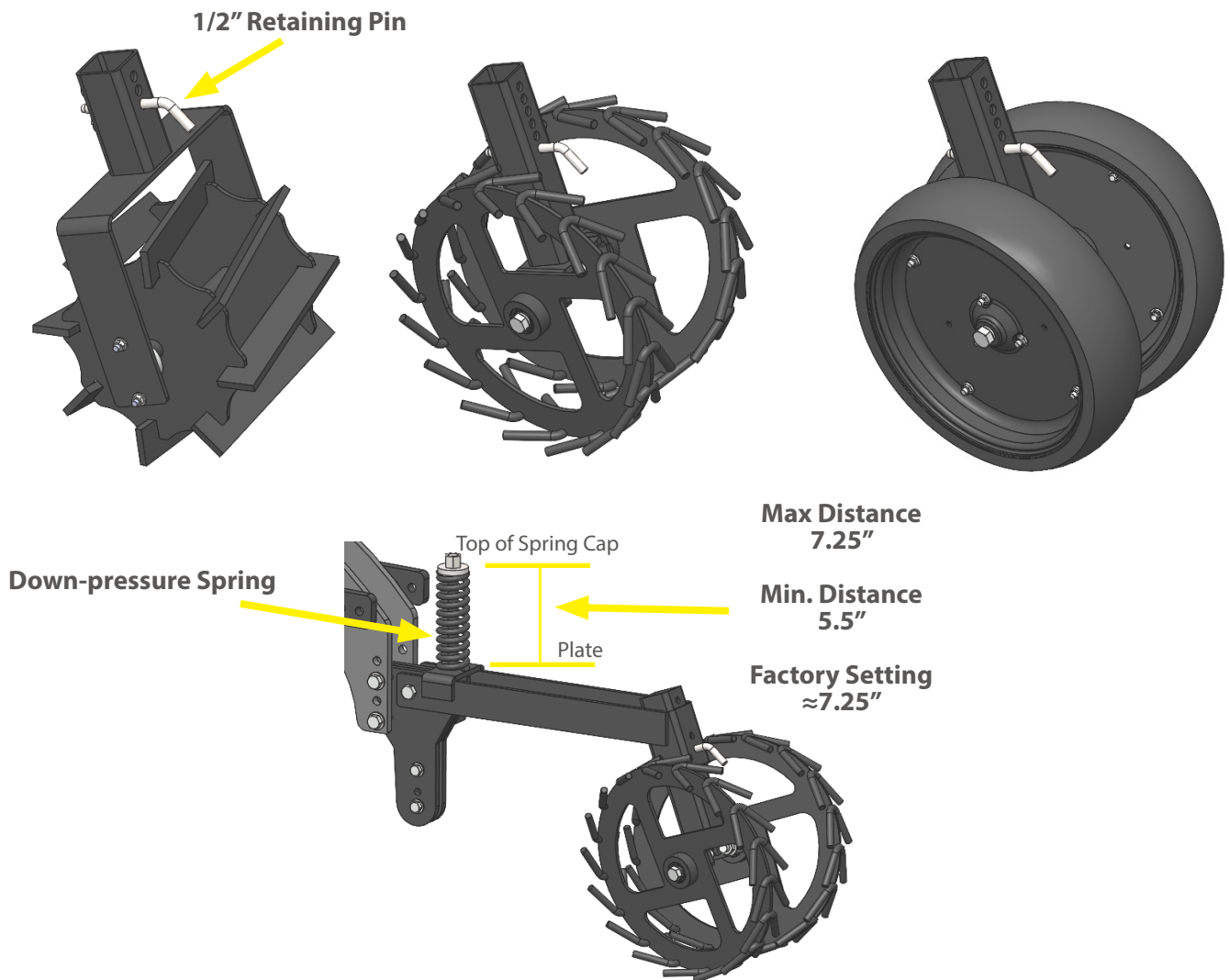



HYDRAULIC TRIPPING UNIT

The hydraulic tripping system uses a pressure relief valve with constant flow from the tractor to allow the knife plate to trip when encountering a hard object in the soil and reset itself automatically.

The resistance to tripping is controlled by the hydraulic system pressure and can be set between 500 and 2500 psi (see page 42 for more details).

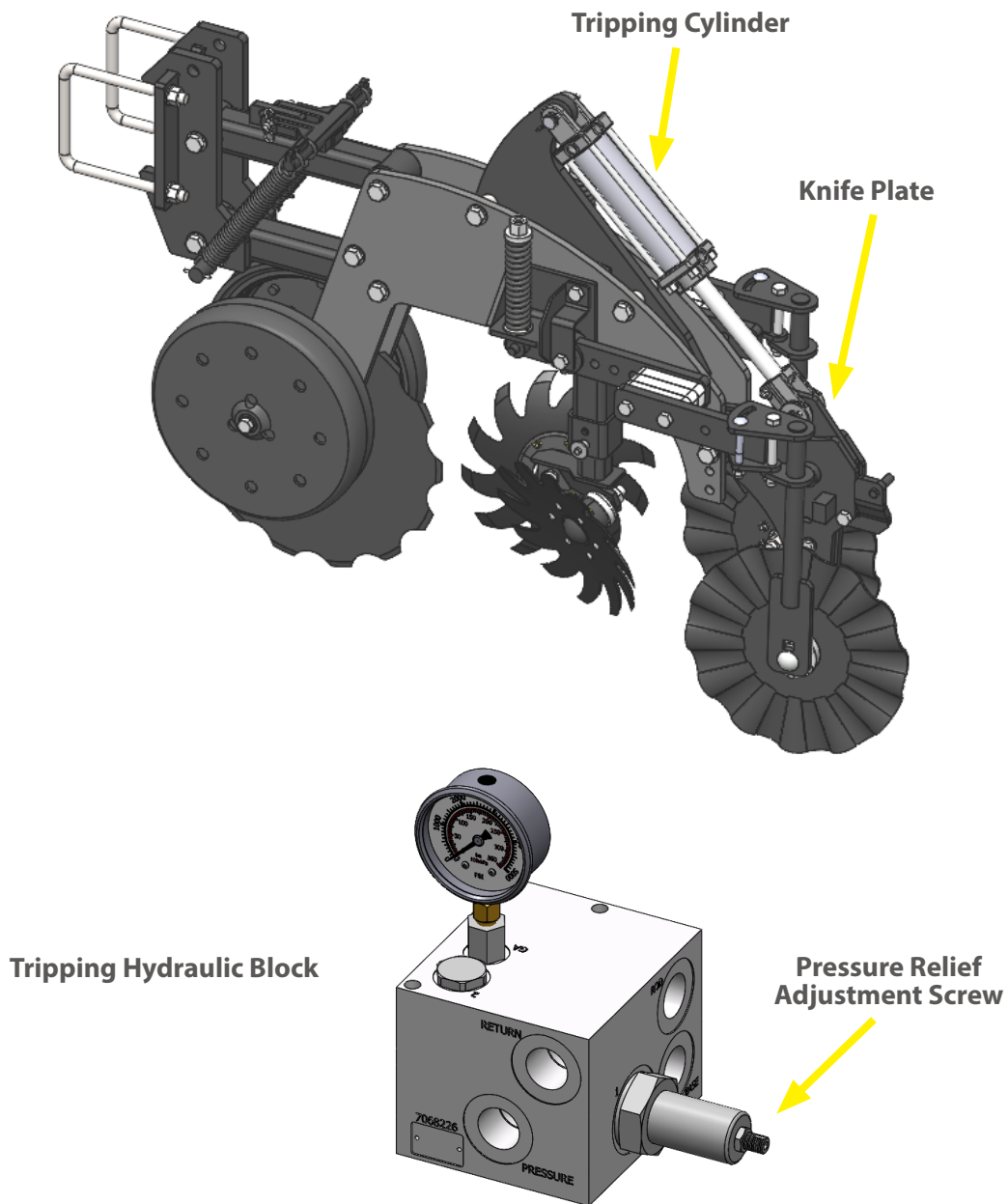



HYDRAULIC TRIPPING SYSTEM - CONNECTING

- Connect the hose from the pressure port on the hydraulic block to the pressure-side SCV port on your tractor.
- Connect the hose from the return port on the hydraulic block to the corresponding return SCV port on your tractor.
- Set the hydraulic SCV connected to the tripping system hoses to run in the constant flow function.
- Set the hydraulic flow of the SCV to 1 to 2 gallons per minute.
- Prepare to check the function of the hydraulic system by making sure all people, animals, and obstructions are clear from the machine.
- Cycle the system through the travel range of the cylinders and check that all rows function as expected.
- Always place the system in “float” when performing work on the row units.
- Pressurize the system and check that the gauge indicates the desired pressure. If not, adjust pressure screw.
- Once you have performed a check and set the system pressure to a good starting point, the machine is ready to go to the field.

Tripping Hydraulic Block

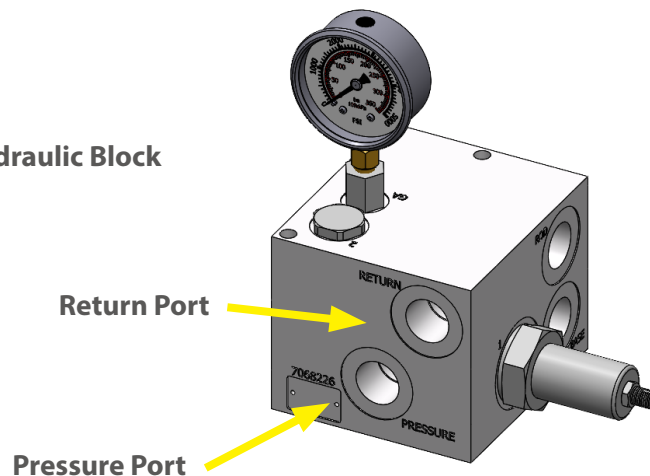

51250



HIGH PRESSURE FLUID - DANGER

Use safe practices. Fluid injection can occur; will result in death or serious injury. Hazards may include, but are not limited to, injury beyond the entry point, over pressurized components, damaged components, components with excessive wear, swollen components, ect.



HYDRAULIC TRIPPING SYSTEM - SETTING PRESSURE

- The tripping force can be adjusted by adjusting system pressure on the hydraulic block.
- Pressure can be adjusted from 500 to 2500psi.
- To increase system pressure (more resistance to tripping) turn the adjustment screw on the hydraulic block clockwise.
- To decrease system pressure (less resistance to tripping) turn the adjustment screw on the hydraulic block counter-clockwise.
- Typically, it is best to set the system to the lowest pressure that keeps the knives in the ground but allows the units to trip when encountering an obstruction. Lower pressures will prolong the life of the system and reduce knife breakage.
- When setting your hydraulic tripping system start between 500 and 1000 psi and work up to find the best pressure for your conditions. **Refer to the chart below for recommended pressure adjustment increments as you get started.**
- Make fine adjustments as you start to find a pressure range that keeps the knives engaged in obstruction-free soil.

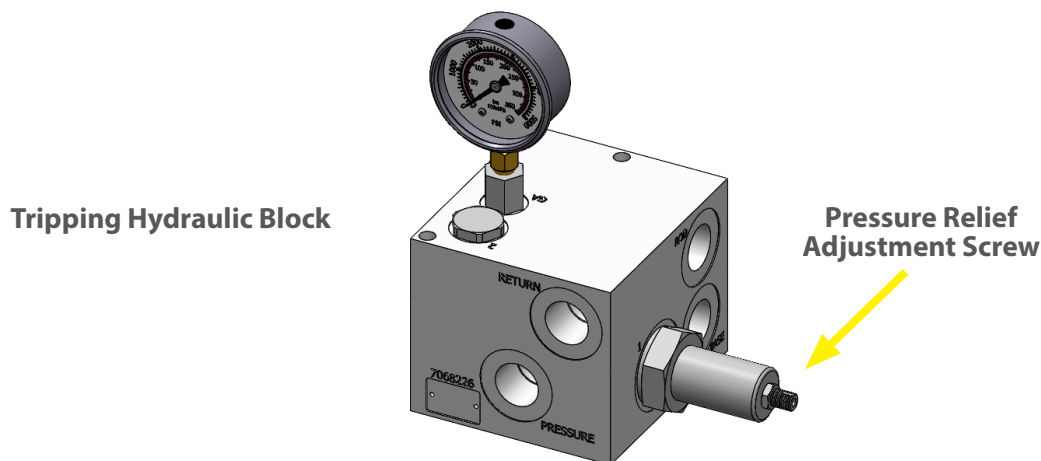

Pressure (PSI)	Increments of Adjustment
500-1000 PSI	250 PSI
1000-1500 PSI	100 PSI
1500-2000 PSI	50 PSI
2000+ PSI	25 PSI



BAR STANDS

- Bar stands on the StripCat™ can be set to various heights to accommodate your machine storage and hookup situation.
- There are multiple hole combinations between the stand tube and the receiver tube to achieve the ideal stand height.
- Generally, it is best to find the setting that allows your machine to sit level when parked on the bar stands in the front with the knives supporting the rear of the machine.
- On soft ground, use wood blocks or steel plates to keep the bar stands and knives from settling into the ground and prevent the machine from becoming unstable or causing difficulties the next time you want to hook up to the machine.
- Prior to unhooking the machine, check that all hydraulic, electrical, and mechanical connections are disconnected.
- Always secure the bar stands in the “up” position before use.

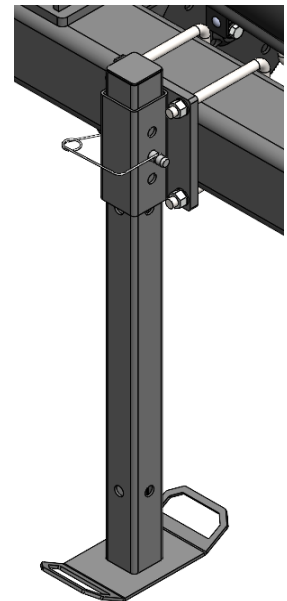
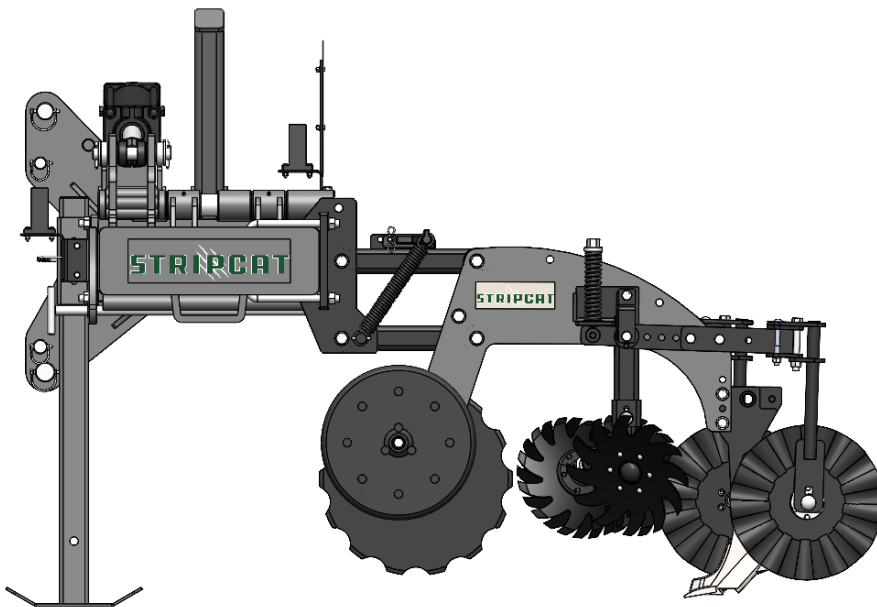



OPERATING TIPS

WHEAT STUBBLE AND SOYBEAN RESIDUE

- In conditions with little residue from the previous crop, the row cleaners may not be necessary and can be adjusted up to not contact the soil or used as normal.

CORN STALKS

- When strip tilling in standing corn stalks, it is recommended to work between the previous rows, next to the rows, or at a slight angle to the rows of stalks.
- When strip tilling on ridges it is recommended to use a root ball puller, stalk chopper, or rolling stalk chopper prior to strip tilling.
- Some experimentation may be necessary to produce the best strips for your conditions.

KNIFE DEPTH

- A steel rod or wooden dowel can be inserted into the middle of the strip to check the depth of action of the knife.
- Adjust the knives to suit your conditions, fertilizer placement needs, and tillage goals.

DRAFT CONTROL

- It may be helpful for overall machine functionality to disable draft control on your tractor. Disabling draft control will “force” the implement into the ground and make the parallel linkages work to keep each row fully engaged.



SPEED RECOMMENDATIONS

A speed of 5 to 6.5 miles per hour is recommended for optimum results. Faster speeds will result in more soil disturbance, knife blowout, and wear on the machine. Slower speeds may result in inconsistent strips.

- Ideal operating speed: 5-6.5 mph
- Minimum operating speed: 4 mph
- Maximum operating speed: 8 mph

SPEED EFFECTS

- In most conditions, speeding up will result in more soil disturbance, knife blowout, and wear on the machine.
- In most conditions, slowing down may result in inconsistent strips.
- See troubleshooting section for more information on performance issues related to speed.



PARKING

For long-term parking, see also “**Storage**” below.

1. Choose a parking location that has room for unfolding, is level, has firm soil and is unlikely to develop soft soil in rain. With the implement still hitched, maneuver it to the parking location.

If the implement must be parked folded, leave it hitched to the tractor. Skip steps 2, 4, and 7.

2. Unfold the implement. Set the fold circuit(s) to Float.
3. Lower the implement to just above ground level at the rear of the row units. Set the tractor remotes to Neutral to hold at slight lift. Shut off the tractor and remove the key.
4. Block up knives to prevent damage or settling.
5. Unplug implement hydraulic hoses and electrical lines from tractor. Set bar stands at appropriate height (see page 43).
6. Start the tractor. Lower the 3-point hitch until the implement is supported by the row units.
7. Disconnect the hitch arms and link.

STORAGE

Store the StripCat™ where children do not play. If possible, store the implement inside for longer life.

1. Thoroughly clean implement.
2. Park the implement at the storage location as per “Parking” above.
3. Lubricate areas noted under “Maintenance & Lube” beginning on page 53. Apply heavy grease to exposed cylinder rods.
4. Inspect implement for worn or damaged parts. Make repairs and service during the off-season.
5. Use spray paint to cover scratches, chips, and worn areas on the implement to protect the metal.
6. Cover with a tarp if stored outside.



TIP OVER/CRUSHING HAZARD AND EQUIPMENT DAMAGE RISK:

Never unhitch, park, or store a partially folded implement. A partially folded implement could topple backward or forward immediately or at a later time, causing serious injury or death and certain severe equipment damage. When unhitched, the implement is supported at the rear only by row unit tools and spring tension. Slopes, soft soils, and soils later softened by rain are particularly dangerous.



FOLLOWING OPERATION

- Store the unit in an area away from human activity.
- Do not park equipment where it will be exposed to livestock for long periods of time. Damage and livestock injury could result.
- Do not permit children to play on or around the stored unit.
- Make sure all parked machines are on a hard, level surface.



PERFORMING MAINTENANCE

- Good maintenance is your responsibility. Poor maintenance is an invitation to trouble.
- Before working on this machine, stop the towing vehicle, set the brakes, shut off the engine and remove the ignition keys.
- Be certain all moving parts on attachments have come to a complete stop before attempting to perform maintenance.
- Always use the proper tools or equipment for the job at hand.
- Use extreme caution when making adjustments.
- Follow the torque chart in this manual when tightening bolts.
- Replace all shields and guards after servicing and before moving.
- After servicing, be sure all tools, parts and service equipment are removed.
- Never replace hex bolts with less than Grade 5 bolts unless otherwise specified. Refer to **Bolt Torque Chart** for head identification marking.
- Where replacement parts are necessary for periodic maintenance and servicing, genuine factory replacement parts must be used to restore your equipment to original specifications. The manufacturer will not claim responsibility for use of unapproved parts and/or accessories and other damages as a result of their use.
- If equipment has been altered in any way from the original design, the manufacturer does not accept any liability for injury or warranty.
- A first aid kit should be kept readily accessible while performing maintenance on this equipment.



STRIPCAT™ DO'S AND DON'TS

- DO follow all safety precautions in this manual.
- DO locate and familiarize yourself with the various Safety Signs and instructional decals prior to operation.
- DO inspect equipment for damage and wear before use; repair as needed.
- DO use caution when connecting pressurized systems, such as hydraulics and pneumatics.
- DO follow recommend maintenance.
- DO level the toolbar for optimum performance.
- DO lift implements completely out of the soil before turning the unit.
- DO use caution when moving large equipment. Using a spotter is recommended when working around obstacles on the ground and/or overhead.
- DON'T fold the toolbar with locking pins in the locked position.
- DON'T over-pressurize the hydraulic system; StripCat™ hydraulics are designed for 3,000 PSI MAX working pressure.
- DON'T exceed the limits of a piece of machinery.
- DON'T modify equipment from factory build; modification may compromise equipment safety and integrity and will void product warranty.

TROUBLESHOOTING



Troubleshooting		
Problem	Possible Cause	Solution
Tooling not engaging with the soil as desired.	Toolbar not running low enough.	Adjust gauge wheels up to allow the toolbar to run lower (see page 26).
		Adjust hitch settings in tractor to allow 3-point hitch to run lower.
	Toolbar not level.	Adjust top link and/or hitch arm heights (see page 25).
	Down pressure springs set too light.	Adjust down pressure springs to a firmer setting.
Row units plug with residue between front coulter and row coulter.	Toolbar height/levelness.	Adjust toolbar height/level.
	Wet/damp conditions preventing good residue flow.	Wait for ground to dry.
		Decrease ground speed to improve residue flow.
		Adjust row cleaners up slightly to decrease residue load.
Bearing going out.	Check/replace bearings.	
Row units plug with residue between row cleaner and knife	Toolbar height/levelness.	Adjust toolbar height/level.
	Too much residue at knife.	Adjust row cleaners down to move more residue away from knife
		Adjust ground speed to improve residue flow.
Wet/damp conditions preventing good residue flow	Adjust ground speed to improve residue flow.	

TROUBLESHOOTING



Troubleshooting		
Problem	Possible Cause	Solution
Row units plug with residue between knife and berm building discs.	Not enough space for residue between knife and discs.	Increase distance between discs and knife by adjusting berm building disc width with poly spacer blocks (see page 37).
		Increase distance between discs and knife by adjusting berm building discs fore & aft on arms (see page 38).
	Heavy residue conditions.	Adjust ground speed to improve residue flow.
	Wet/damp conditions preventing good residue flow.	Adjust ground speed to improve residue flow.
Residue plugs between row units.	Not enough space for residue between knife and discs.	Adjust distance between discs and knife by adjusting berm building disc width with poly spacer blocks (see page 37).
		Adjust distance between discs and knife by adjusting berm building discs fore & aft on arms (see page 38).
	Heavy residue conditions.	Adjust ground speed to improve residue flow.
	Wet/damp conditions preventing good residue flow.	Adjust ground speed to improve residue flow.
Discs not turning.	Bearing going out.	Check/replace bearings.
	Obstruction holding disc in place.	Remove obstruction.
Berm isn't sized/shaped as desired.	Berm building discs not optimized.	Adjust berm building disc down pressure/angle to optimize berm.
	Rear finishing tool not optimized.	Adjust rear finishing tool.



HYDRAULIC TRIPPING SYSTEM

Troubleshooting		
Problem	Possible Cause	Solution
System trips too easily/knives won't stay engaged.	Pressure relief valve set too low.	<p>Increase system pressure. Pressure adjustments should be made in 25 psi increments, as small changes to pressure can have a large effect on tripping force.</p> <p>NOTE: Do not make changes to hydraulic flow from tractor.</p>
Knives are shearing bolts, system is not tripping.	Pressure relief valve set too high.	<p>Decrease system pressure. Pressure adjustments should be made in 25 psi increments, as small changes to pressure can have a large effect on tripping force.</p> <p>NOTE: Do no make changes to hydraulic flow from tractor.</p>



MAINTENANCE

- Proper maintenance will ensure longevity and optimum performance of your Hawkins equipment.
- Visual inspection is recommended before each use. Check for loose bolts, worn parts, cracked welds and other damage. Replace and repair as needed.
- In addition to visual inspection before each use, carefully inspect hydraulic components every 100 hours for leaks, excessive wear, swelling and damage. Leaks should be corrected by tightening the fittings according to the **Hydraulic Fitting Torque Chart** or replacing components. Replace any components showing signs of excessive wear, swelling or damage.
- Always replace bolts with the same grade, refer to **Bolt Torque Chart** for grade identification. Tighten bolts according to **Bolt Torque Chart**.
- Always replace parts with Hawkins parts only.
- We recommend greasing each grease zerk on the toolbar hinge weekly. Grease all attachment grease zerks weekly, or according to specified lubrication schedule.
- Before long-term storage (3 months or more) clean debris from equipment and touch-up paint to prevent corrosion.
- Store in a flat dry place away from human activity and livestock.
- After long-term storage (3 months or more) visually inspect equipment and carefully inspect all components. Especially parts more easily affected by weather damage, such as hydraulic hoses and wiring. Repair and replace as needed before use.



DAILY MAINTENANCE

1. Inspect row units for any loose or missing hardware.

WEEKLY MAINTENANCE

1. Grease the toolbar hinges - three (3) grease zerks on each hinge.
2. Grease gauge wheel bearings.

YEARLY MAINTENANCE

1. Clean machine off.
2. Grease all grease zerks.
3. Replace all parts as necessary.
4. Check Bolt Torque on Hubs.

Toolbar Hinge

Gauge Wheel

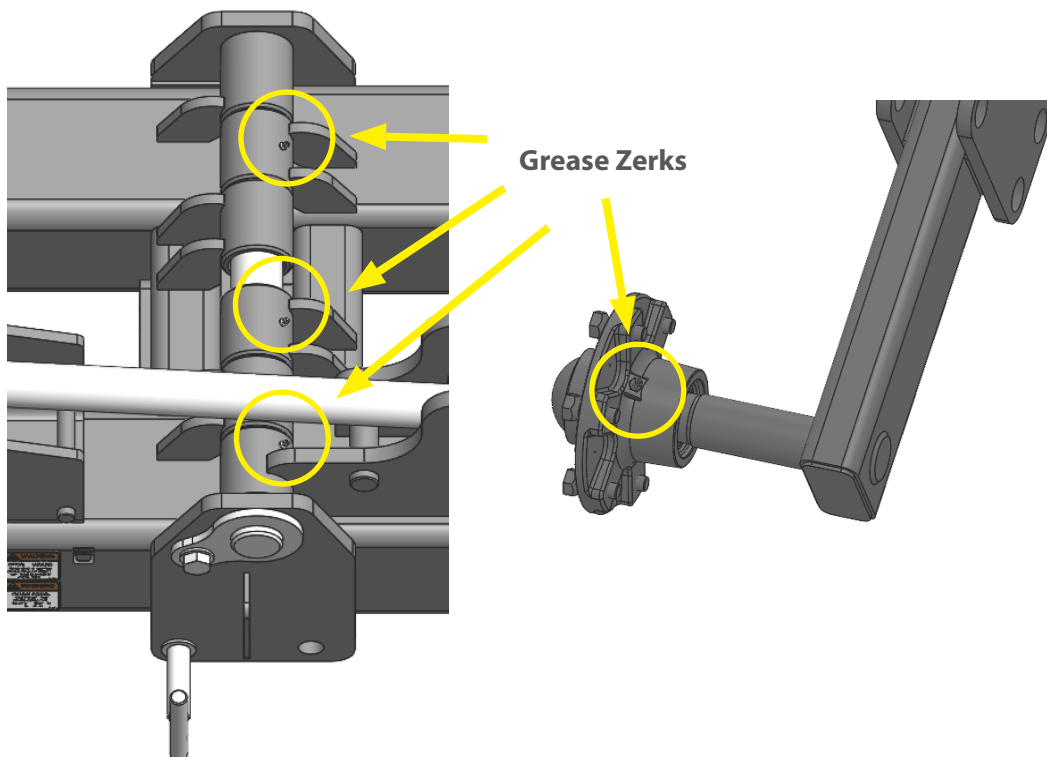



BLEEDING FOLD HYDRAULICS

To function properly, the hydraulics must be free of air. If hydraulics have not been bled, they will operate with jerky, uneven motions and could cause wings to drop rapidly during folding or unfolding. If hydraulics were not bled during initial implement setup or if you replace a part in hydraulic system during the life of the implement, complete the following procedures:

1. Check hydraulic fluid level in tractor reservoir and fill to proper level. Add fluid to system as needed.
2. With implement unfolded and fold cylinders completely extended, disconnect rod end pins and swing the cylinders so they will not contact anything when extended.
3. Loosen rod end hose fittings (1) at a ORB connection.
4. Slowly supply oil to rod end of fold cylinders until oil appears at loosened hose fitting. Tighten fitting and completely retract fold cylinders.
5. With cylinders completely retracted, loosen base end hose fittings (2) at ORB connection.
6. Slowly supply oil to base end of fold cylinders until oil appears at loosened hose fitting. Tighten base end hose fitting and cycle fold cylinders in and out several times.
7. Re-pin cylinder rod clevises.

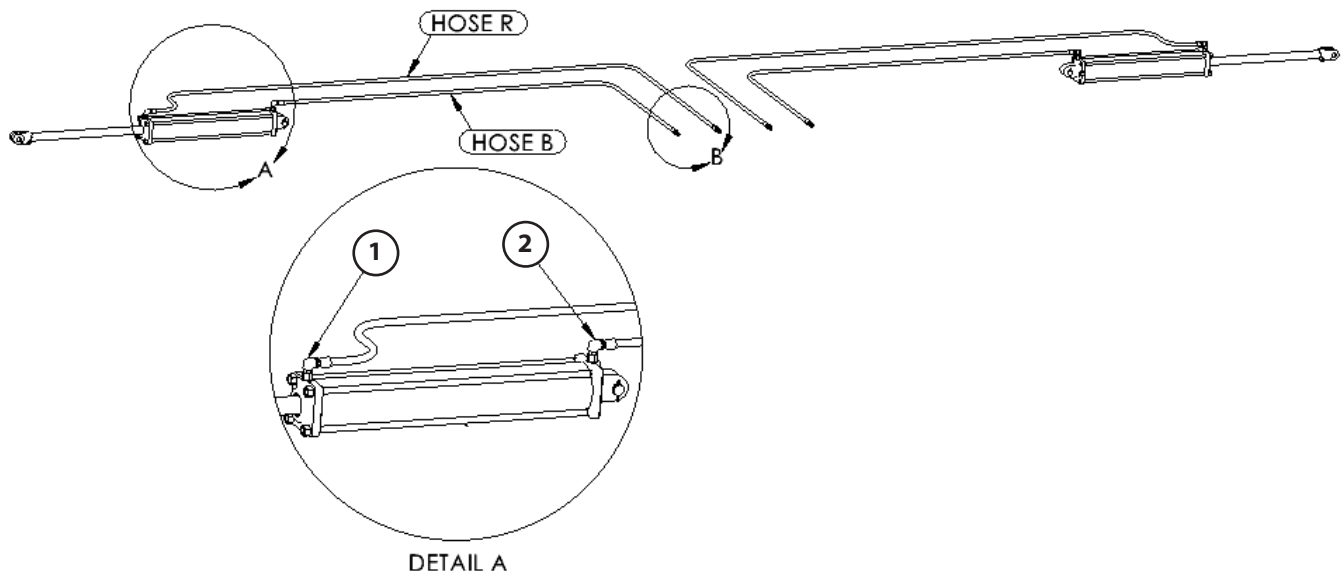

HIGH PRESSURE FLUID - DANGER

- Use safe practices. Fluid injection can occur; will result in death or serious injury.
- Hazards may include, but are not limited to, injury beyond the entry point, over pressurized components, damaged components, components with excessive wear, swollen components, ect.



CHECKING BOLT TORQUE

The table shown below gives correct torque values for various bolts and capscrews. Tighten all bolts to the torques specified in chart unless otherwise noted. Check tightness of bolts periodically, using bolt torque chart as a guide. Replace hardware with the same grade bolt.

BOLT TORQUE CHART

Torque Specifications						
Bolt Diameter	Bolt Torque*					
	SAE Grade 2		SAE Grade 5		SAE Grade 8	
INCH	lbft	(Nm)	lbft	(Nm)	lbft	(Nm)
1/4	6	(8)	9	(12)	12	(17)
5/16	10	(13)	19	(25)	27	(36)
3/8	20	(27)	33	(45)	45	(63)
7/16	30	(41)	53	(72)	75	(100)
1/2	45	(61)	80	(110)	115	(155)
9/16	70	(95)	115	(155)	165	(220)
5/8	95	(128)	160	(215)	220	(305)
3/4	165	(225)	290	(390)	400	(540)
7/8	170	(230)	420	(570)	650	(880)
1	226	(345)	630	(850)	970	(1320)

BOLT HEAD IDENTIFICATION

Grade 2

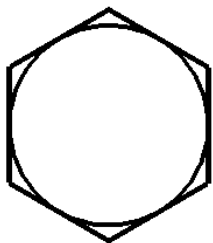

Grade 5

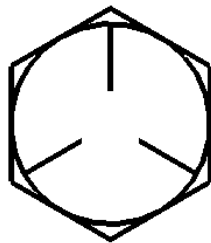

Grade 8

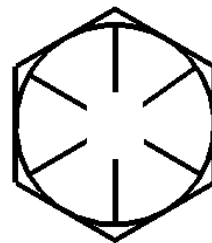



HYDRAULIC FITTING IDENTIFICATION

Hydraulic fitting styles, types and sizes are numerous and at times easily confused. The chart below shows the most common types and sizes of hydraulic fittings for the industry, male ends depicted. This chart is printed at 1 to 1 for ease of identification.

NPTF (National Pipe Taper Fuel) uses tapered threads to create a seal.

ORB (O-Ring Boss) uses an O-ring to seal after threads.

JIC (Joint Industry Council) 37-degree flare sealing surface before threads.

ORFS (O-Ring Face Seal) uses an O-ring to seal before threads.



-4 NPTF



-4 ORB



-4 JIC



-4 ORFS

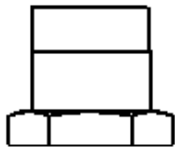

-6 NPTF



-6 ORB

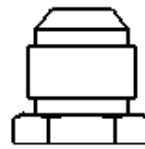

-6 JIC

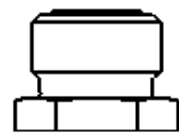

-6 ORFS

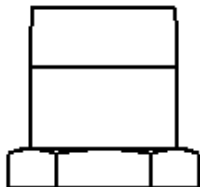

-8 NPTF



-8 ORB

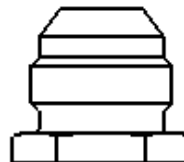

-8 JIC

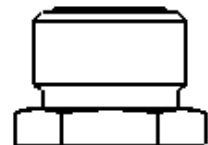

-8 ORFS

N/A



-10 ORB

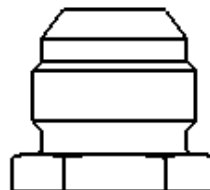

-10 JIC

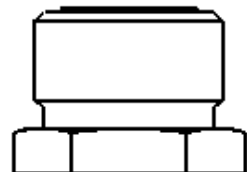

-10 ORFS

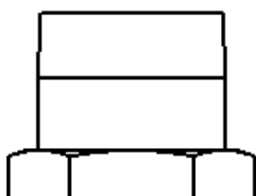

-12 NPTF

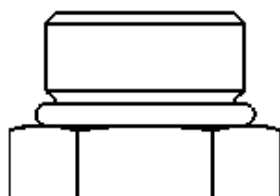

-12 ORB

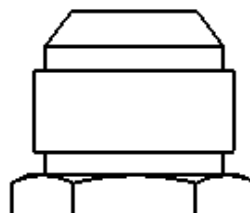

-12 JIC

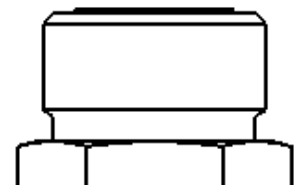

-12 ORFS



CHECKING HYDRAULIC FITTINGS

- Before connecting hydraulic fittings, check that fittings are clean and undamaged. Replacement fittings and hoses are available from StripCat™.
- Ensure O-ring(s) are installed properly as shown in the image. (ORB fitting above, ORFS fitting below)
- “Wet Torque” fittings according to the chart below. Wet Torque is the process of lubricating all threads, O-rings and sealing surfaces with the hydraulic fluid used in the system. Then tightening to a specified torque.
- Do not force fittings together. Ensure male and female are of the same type and size, align sealing surfaces and threads properly.
- Do not apply force to a connection or use the connection as support. Doing so may damage components and/or cause the connection to leak.

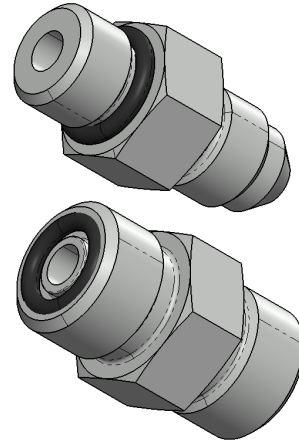

HYDRAULIC FITTING TORQUE CHART

Dash Size	Torque lbft (Nm)			
	NPTF	ORB	JIC	ORFS
-4	12-16 (16-22)	10-15 (14-20)	11-13 (15-18)	10-12 (14-16)
-6	14-32 (19-43)	17-21 (23-28)	20-22 (27-30)	18-20 (24-27)
-8	32-40 (43-54)	30-35 (41-47)	43-47 (58-64)	32-35 (43-47)
-10	-	30-35 (41-47)	55-65 (75-88)	45-50 (61-68)
-12	40-48 (54-65)	30-35 (41-47)	80-90 (108-122)	65-70 (88-95)



TOOLBAR MOUNT AND PARALLEL LINKAGE

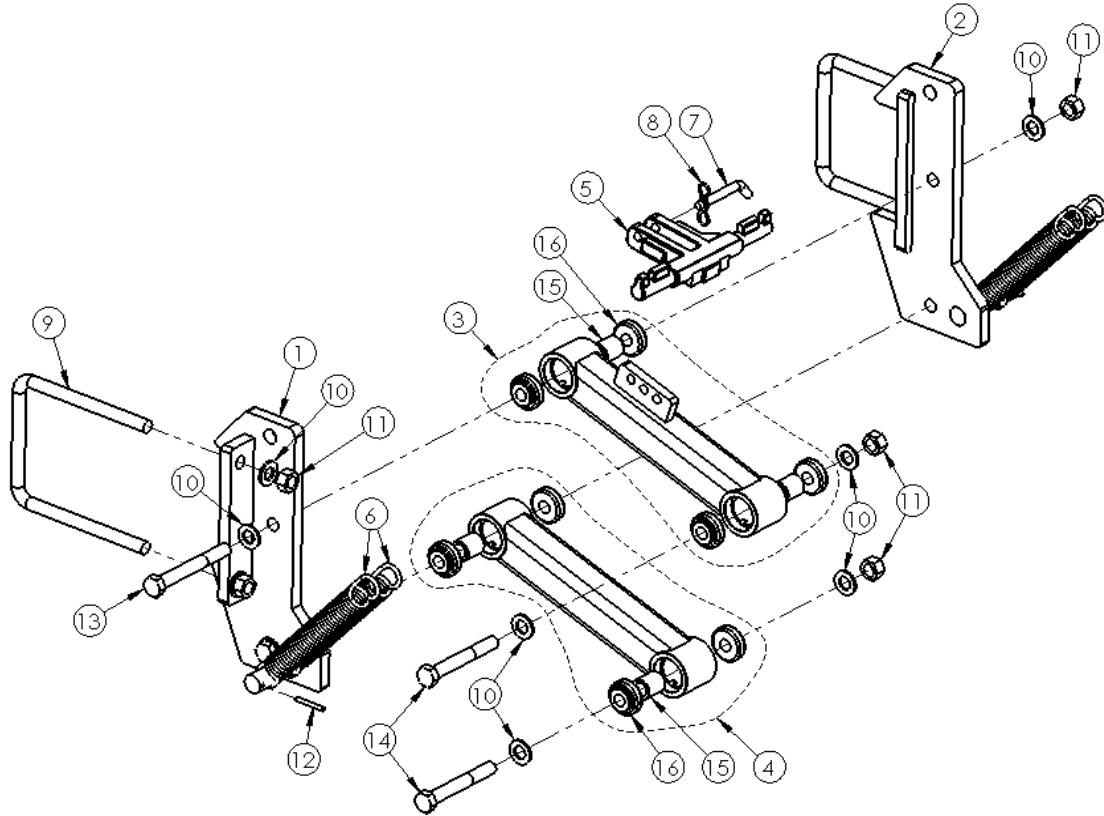

Item Number	Part #	Description	Quantity
1	333046	LH MOUNT	1
2	333047	RH MOUNT	1
3	333012	TOP PARALLEL ARM ASSEMBLY	1
4	333011	BOTTOM PARALLEL ARM ASSEMBLY	1
5	333014	PARALLEL LINK SPRING RETAINER	1
6	333150	PARALLEL LINK SPRING	4
7	333020	BENT PIN	1
SEE NEXT PAGE FOR REMAINING PARTS LIST			



TOOLBAR MOUNT AND PARALLEL LINKAGE

Item Number	Part #	Description	Quantity
8	333021	COTTER PIN BOW TIE	1
9	415004	3/4-10 X 7 X 9 UBOLT	2
10	413072	3/4 FLAT WASHER SAE Z/C	12
11	410012	3/4-10 NUT CENTER LOCK Z/C	8
12	305113	1/4 X 2 ROLL PIN	4
13	411597	3/4-10 X 6 GR 5 BOLT	2
14	411595	3/4-10 X 5.5 GR5 ZP BOLT	2
15	333009	PARALLEL ARM BEARING SPACER	4
16	333010	PARALLEL ARM BEARING	8



SIDEPLATE & ROW CLEANER STEM

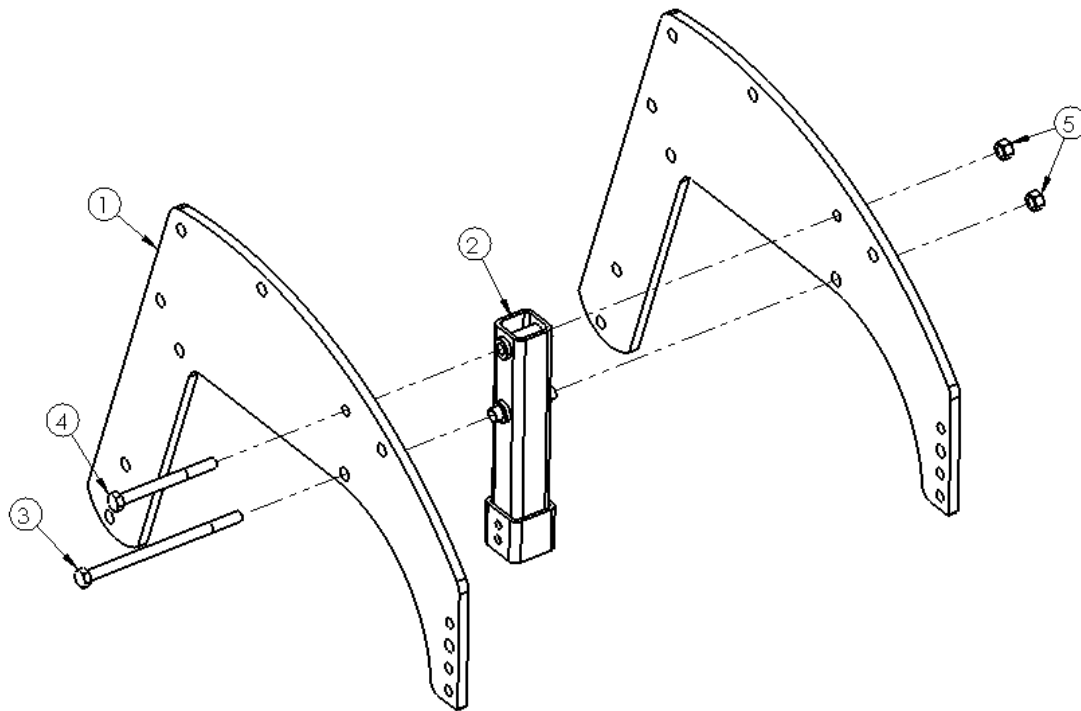

Item Number	Part #	Description	Quantity
1	333035	SIDEPLATE	2
2	333049	STEM	1
3	411241	5/8-11 X 10.5 GR5 Z/C BOLT	1
4	411240	5/8-11 X 6.5 GR5 Z/C BOLT	1
5	410009	5/8-11 NUT CENTER LOCK GR2 Z/C	2



FRONT COULTER

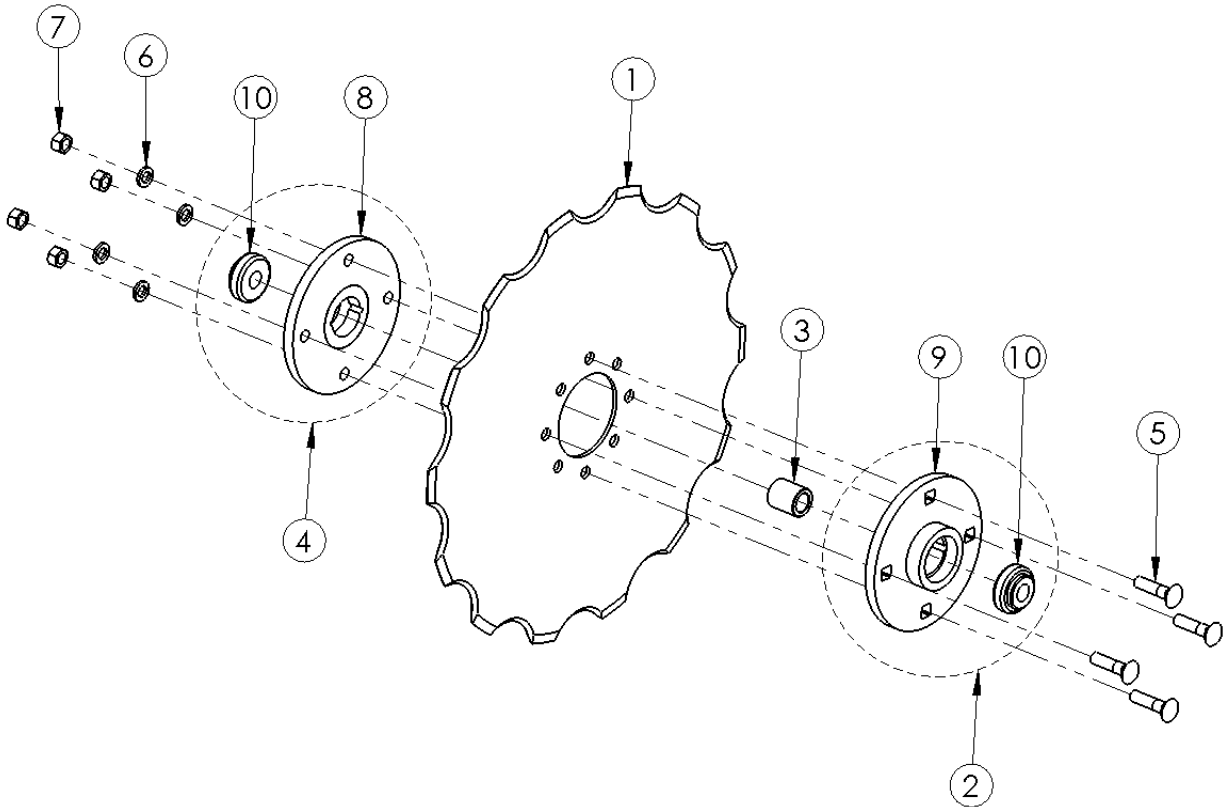

Item Number	Part #	Description	Quantity
1	333155	20" NOTCHED COULTER BLADE	1
2	333161	SQUARE HOLE HUB W/ BEARING	1
3	333009	BEARING SPACER	1
4	333166	ROUND HOLE HUB W/ BEARING	1
5	411733	1/2-13 X 2 CARRIAGE BOLT GR5	4
6	413508	1/2 LOCK WASHER	4
7	412058	1/2-13 NUT GR5	4
8	333164	ROUND HOLE HUB	1
9	333159	SQUARE HOLE HUB	1
10	333010	3/4" BORE BEARING	2



DEPTH GAUGE WHEEL

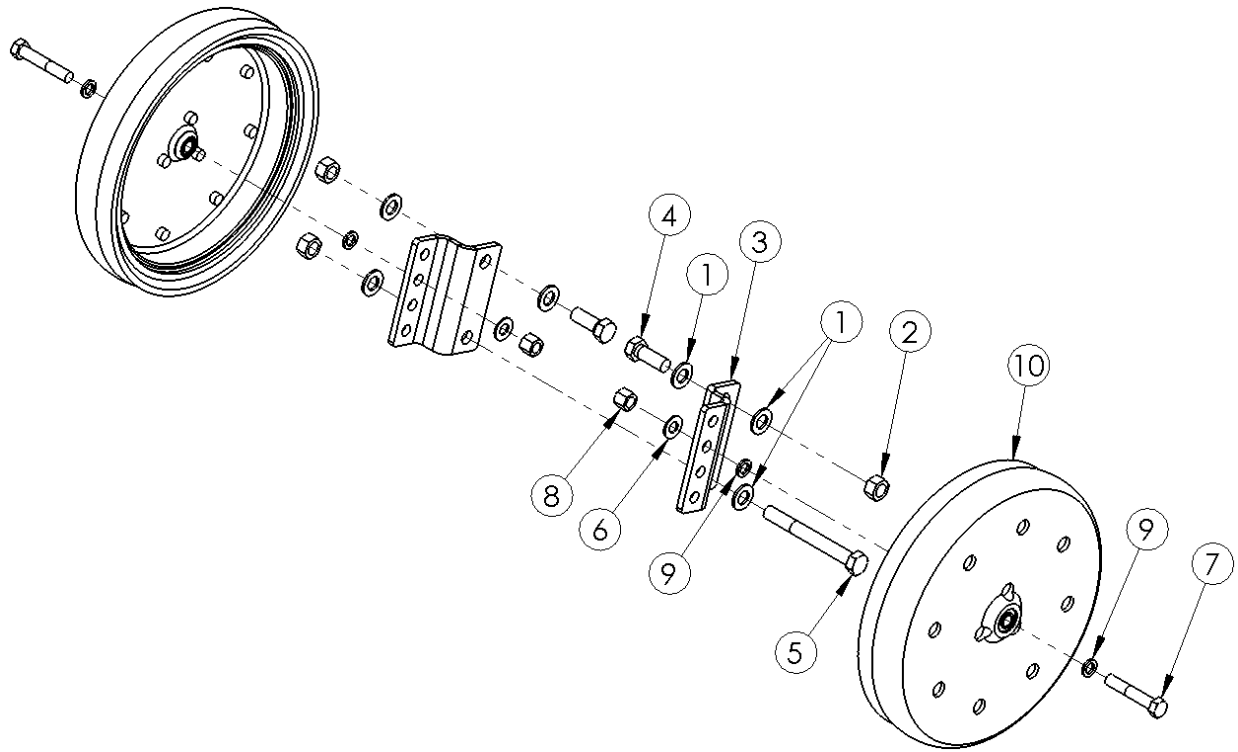

Item Number	Part #	Description	Quantity
1	413072	3/4 FLAT WASHER SAE	6
2	410012	3/4-10 NUT CENTER LOCK	3
3	333048	GAUGE WHEEL BRACKET	2
4	411584	3/4-10 X 2 GR.5 BOLT	2
5	411598	3/4-10 X 6.5 GR.5 BOLT	1
6	413011	5/8 FLAT WASHER SAE	2
7	411565	5/8-11 X 3.5 GR.5 BOLT	2
8	409009	5/8-11 NUT NYLON LOCK	2
9	333205	5/8 WASHER	4
10	333201	3IN POLY GAUGE WHEEL	2



INDEPENDENT BERM BUILDER - MOUNT

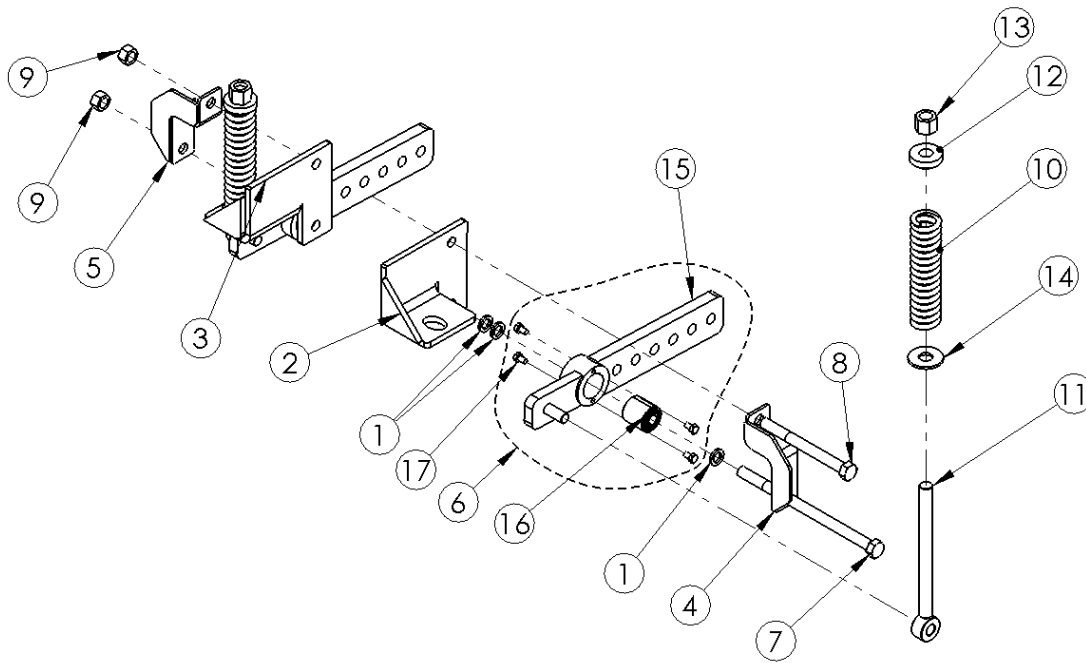

Item Number	Part #	Description	Quantity
1	333205	5/8 WASHER	6
2	333040	IBB LEFT SIDE MOUNT BRACKET	1
3	333038	IBB RIGHT SIDE MOUNT BRACKET	1
4	333054	IBB RIGHT SIDE SUPPORT BRACKET	1
5	333055	IBB LEFT SIDE SUPPORT BRACKET	1
6	333103	IBB ARM ASSEMBLED	2
7	411241	5/8-11 X 10.5 GR5 BOLT	1
8	411240	5/8-11 X 6.5 GR5 BOLT	1
		SEE NEXT PAGE FOR REMAINING PARTS LIST	



INDEPENDENT BERM BUILDER - MOUNT

Item Number	Part #	Description	Quantity
9	410009	5/8-11 NUT CENTER LOCK GR2	2
10	333091	COIL SPRING	2
11	333117	SPRING PULL ROD	2
12	333072	SPRING CAP	2
13	305101	3/4-10 NUT NYLON LOCK	2
14	413012	3/4 FLAT WASHER USS	2
15	333070	IBB ARM NO BEARING	2
16	333097	5/8 BORE BEARING	2
17	411117	5/8-18 X 5 GR.5 BOLT	8



INDEPENDENT BERM BUILDER - REAR ARMS

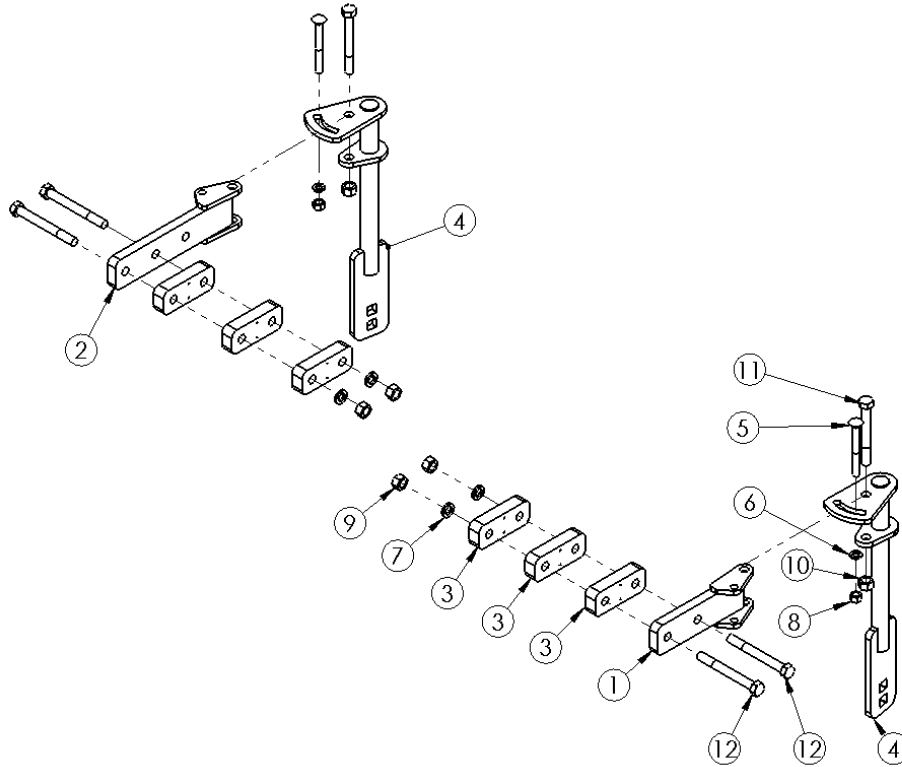

Item Number	Part #	Description	Quantity
1	333059	IBB ADJUSTABLE ARM SHORT	1
2	333221	IBB ADJUSTABLE ARM LONG	1
3	333068	1 IN. POLY SPACER	6
4	333067	IBB DISK ARM	2
5	411737	1/2-13 X 4 1/2 CARRIAGE BOLT GR5	2
6	413508	1/2 LOCK WASHER	2
7	413510	5/8 LOCK WASHER	4
8	412058	1/2-13 NUT GR5	2
9	412060	5/8-11 NUT GR.5	4
10	410009	5/8-11 NUT CENTER LOCK GR.2	2
11	411568	5/8-11 X 5 GR5 BOLT	2
12	305112	5/8-11 X 5.5 GR.5 BOLT	4



INDEPENDENT BERM BUILDER - COULTER & HUB

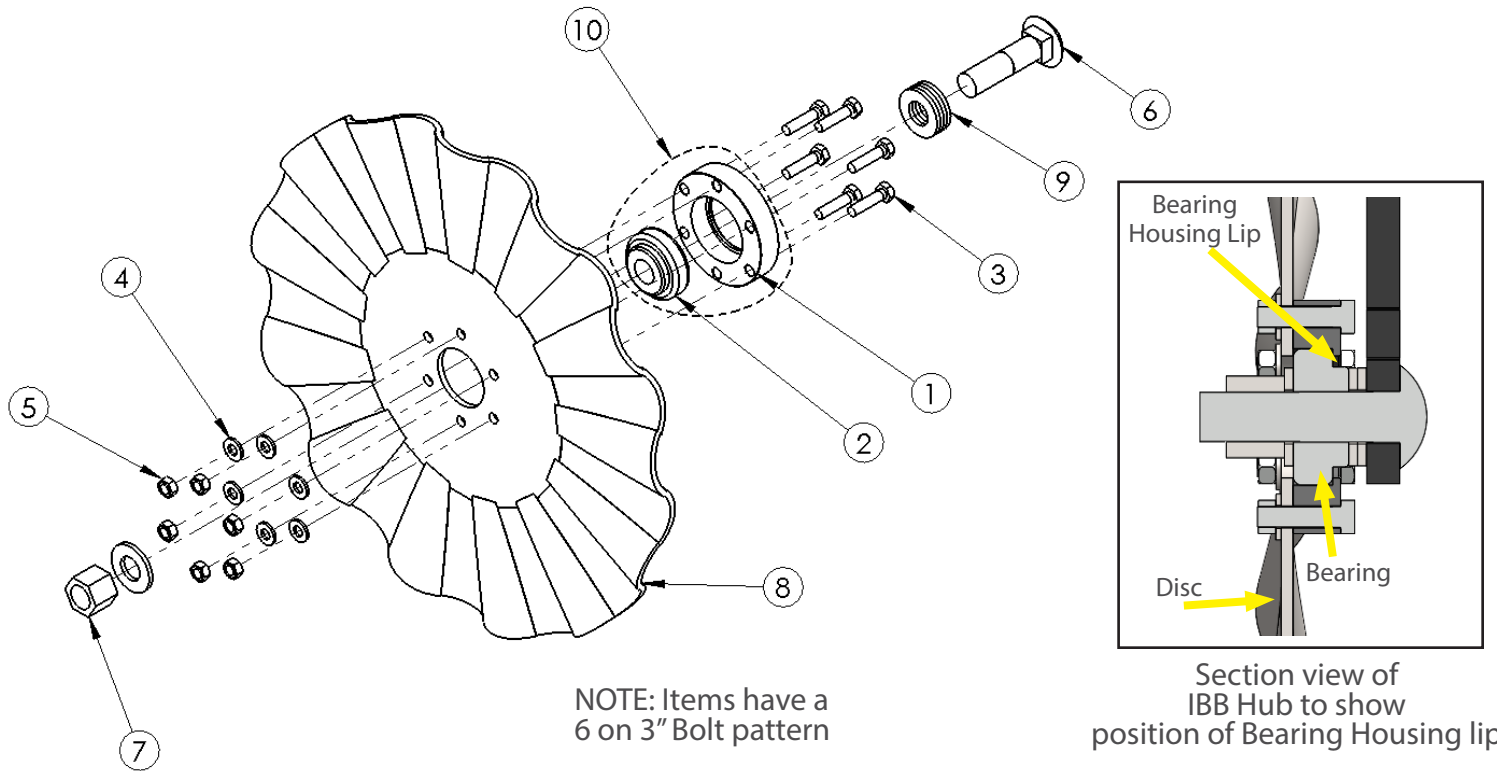

NOTE: Items have a 6 on 3" Bolt pattern

Section view of IBB Hub to show position of Bearing Housing Lip

Item Number	Part #	Description	Quantity
1	333104	IBB HUB	1
2	333010	3/4" BORE BEARING	1
3	411122	5/16-18 X 1.25 GR5 BOLT	6
4	413005	5/16 FLAT WASHER SAE	6
5	412055	5/16-18 NUT GR5	6
6	411793	3/4-10 X 3 CARRIAGE BOLT GR5	1
7	305101	3/4-10 HEX NYLON LOCK NUT	1
8	333118	16" 13 WAVE BLADE	1
9	333154	3/4 X 1 1/2 MACHINE WASHER	5
10	333199	IBB HUB WITH BEARING	1



KNIFE PLATE - RIGID

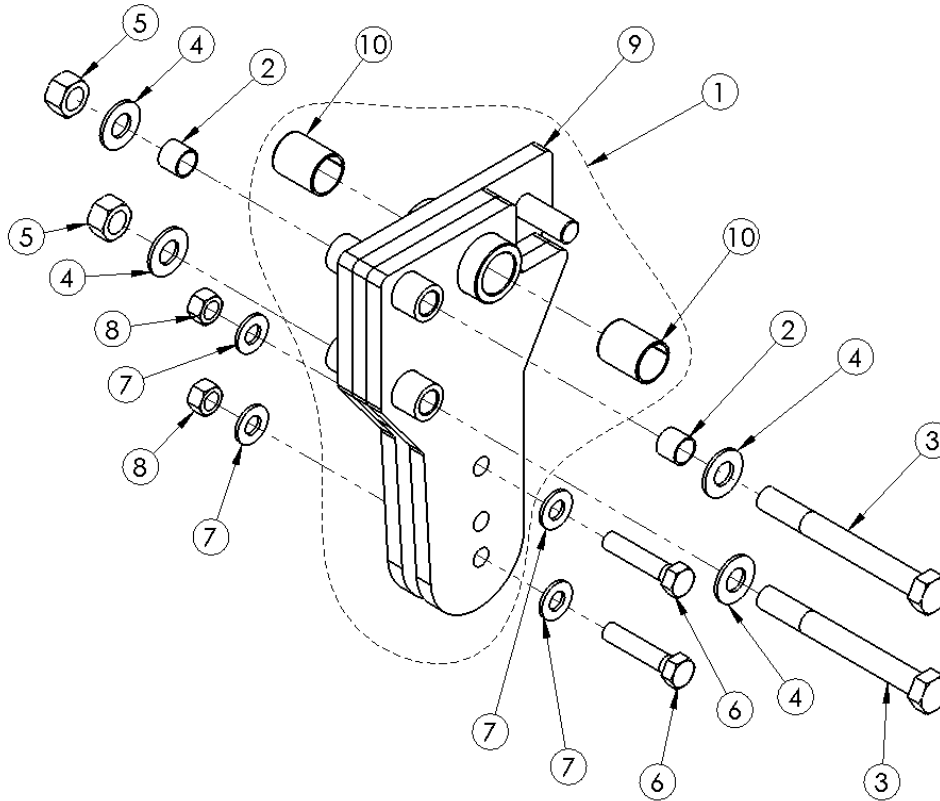

Item Number	Part #	Description	Quantity
1	333050	RIGID KNIFE PLATE ASSEMBLY	1
2	333029	3/4 OD BUSHING	2
3	411569	"5/8-11 X 5.5 GR.5 BOLT"	2
4	413011	5/8 FLAT WASHER SAE	4
5	410009	5/8-11 NUT CENTER LOCK GR.2	2
6	411185	1/2-13 X 2 1/4 GR.5 BOLT	2
7	413007	1/2 FLAT WASHER SAE	4
8	412058	1/2-13 NUT GR.5 BOLT	2
9	333028	RIGID KNIFE PLATE	1
10	333172	SLEEVE BUSHING	2



REAR ACCESSORY MOUNT

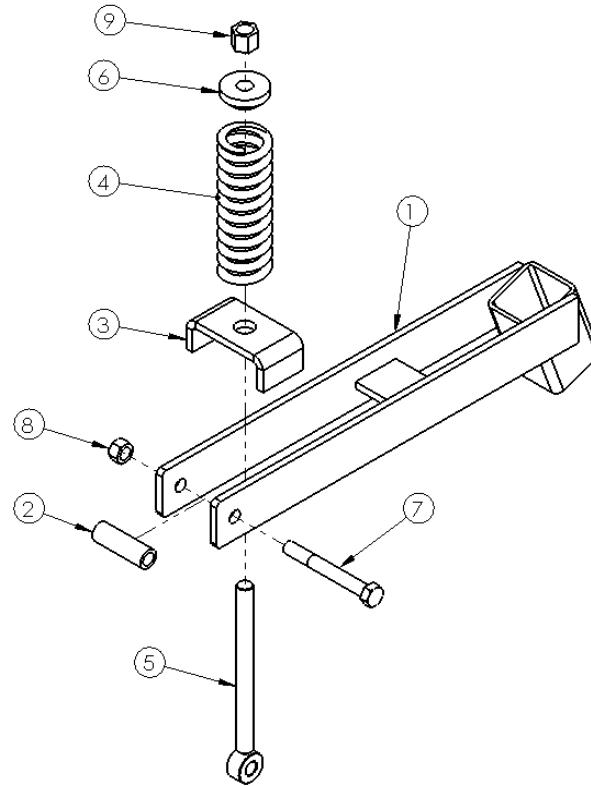

Item Number	Part #	Description	Quantity
1	333109	REAR ACCESSORY ARM	1
2	333111	1" OD BUSHING	1
3	333116	SPRING PLATE	1
4	333197	COMPRESSION SPRING	1
5	333117	SPRING PULL ROD	1
6	333113	SPRING CAP	1
7	411568	5/8-11 X 5 GR.5 BOLT	1
8	410009	5/8-11 NUT CENTER LOCK GR.2	1
9	305101	3/4-10 HEX NUT NYLON LOCK	1



ROLLING BASKET

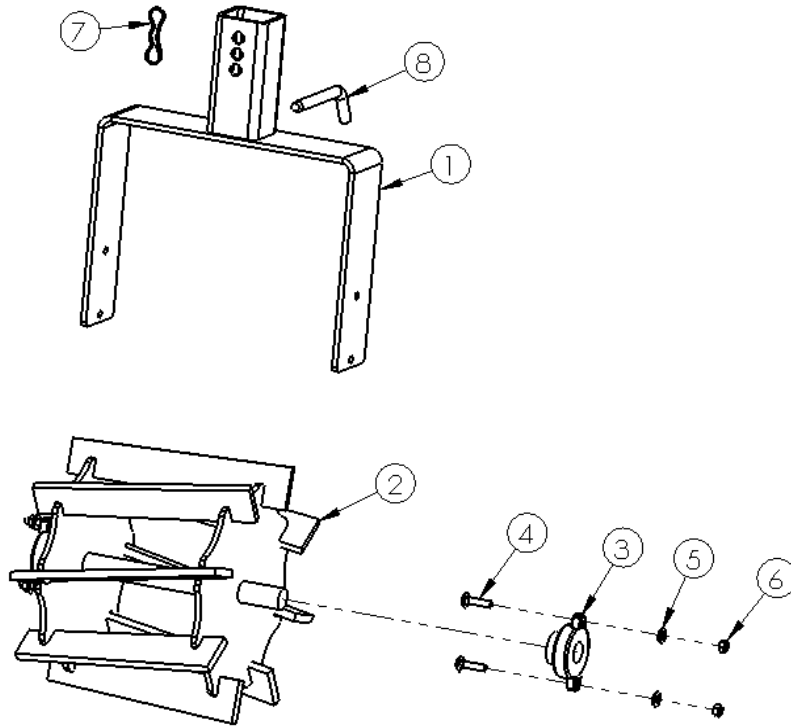

Item Number	Part #	Description	Quantity
1	333096	BASKET FRAME	1
2	333089	BASKET	1
3	333051	BEARING	2
4	411718	5/16-18 X 1 1/4 CARRIAGE BOLT	4
5	413005	5/16 FLAT WASHER SAE Z/C	4
6	412055	5/16-18 NUT Z/C	4
7	333021	COTTER PIN BOW TIE	1
8	333099	1/2 X 4 BENT PIN	1



PACKING WHEELS

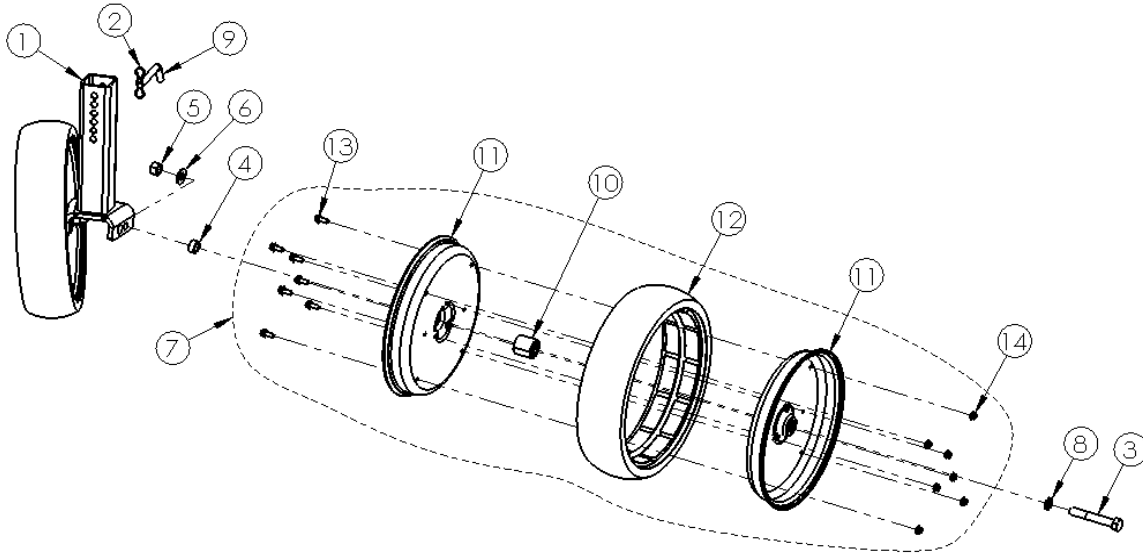

Item Number	Part #	Description	Quantity
1	333127	ADJUSTABLE STEM	1
2	333021	COTTER PIN BOW TIE .120 WIRE X 2.75 OAL	1
3	411222	5/8-11 X 4 GR5 Z/C	2
4	333077	SPACER .688 ID X 1.00 OD	2
5	410009	5/8-11 NUT CENTER LOCK GR2 Z/C	2
6	413011	5/8 FLAT WASHER SAE Z/C	2
7	333136	4 X 16 POLY WHEEL	2
8	333205	10GA X 5/8 X 1 MACHINE BUSHING	2
9	333099	1/2 X 4 BENT PIN	1
10	333097	5/8 BEARING	2
11	333214	RIM HALF 4 X 16	4
12	333213	RUBBER TIRE 4 X 16	2
13	305090	5/16-18 X 3/4 SERRATED FLANGE BOLT GR5 Z/C	14
14	305091	5/16-18 X 3/4 SERRATED FLANGE CH Z/C	14



IRON TIRES

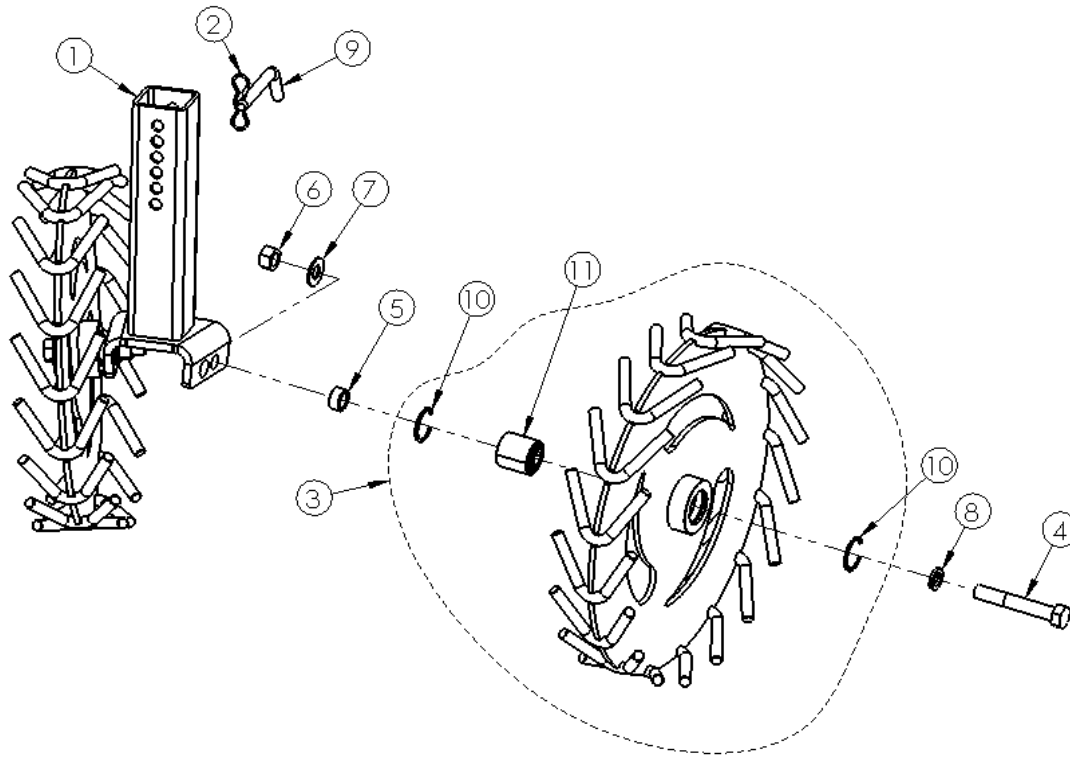

Item Number	Part #	Description	Quantity
1	333127	ADJUSTABLE STEM	1
2	333021	COTTER PIN BOW TIE	1
3	333152	STEEL WHEEL ASSEMBLY	2
4	411222	5/8-11 X 4 GR5 Z/C BOLT	2
5	333077	SPACER .688 ID X 1.00 OD	2
6	410009	5/8-11 NUT CENTER LOCK GR2 Z/C	2
7	413011	5/8 FLAT WASHER SAE Z/C	2
8	333205	10GA X 5/8 X 1 MACHINE BUSHING	2
9	333099	1/2 X 4 BENT PIN	1
10	333151	40MM INTERNAL RETAINING RING	2
11	333097	5/8 BEARING	1



LEFT ROW CLEANER ASSEMBLY

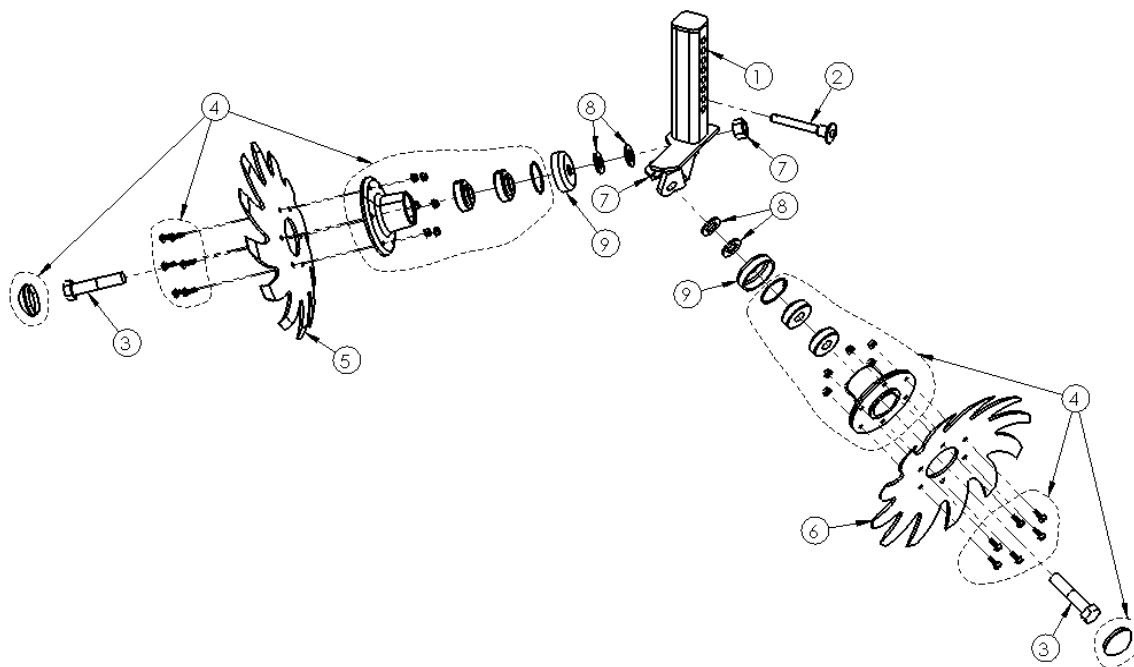

Item Number	Part #	Description	Quantity
1	333183	LH STEM	1
2	416615	1/2 X 3 PUSH BUTTON QUICK RELEASE PIN	1
3	411590	3/4-10 X 3 1/2 GR5 Z/C BOLT	2
4	333186	HUB ASSEMBLY	2
5	333185	RH NOTCHED BLADE	1
6	333176	LH NOTCHED BLADE	1
7	410012	3/4-10 NUT CENTER LOCK Z/C	2
8	413072	3/4 FLAT WASHER SAE Z/C	4
9	333173	BEARING SHIELD	2



RIGHT ROW CLEANER ASSEMBLY

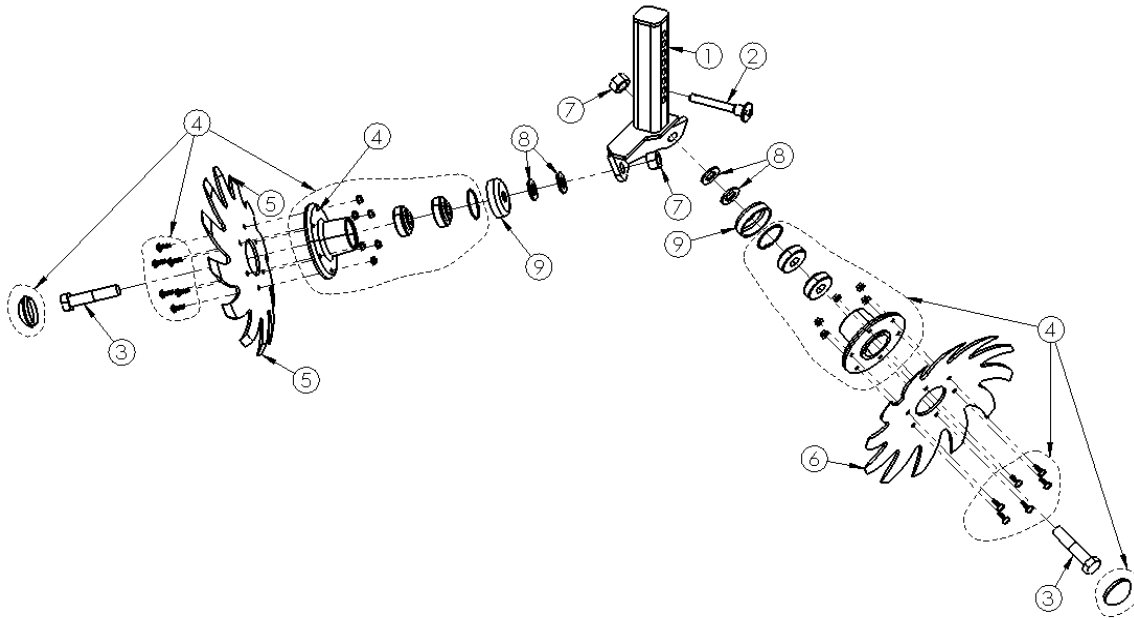

Item Number	Part #	Description	Quantity
1	333187	RH STEM	1
2	416615	1/2 X 3 PUSH BUTTON QUICK RELEASE PIN	1
3	411590	3/4-10 X 3 1/2 GR5 Z/C BOLT	2
4	333186	HUB ASSEMBLY	2
5	333185	RH NOTCHED BLADE	1
6	333176	LH NOTCHED BLADE	1
7	410012	3/4-10 NUT CENTER LOCK Z/C	2
8	413072	3/4 FLAT WASHER SAE Z/C	4
9	333173	BEARING SHIELD	2



HYDRAULIC TRIP

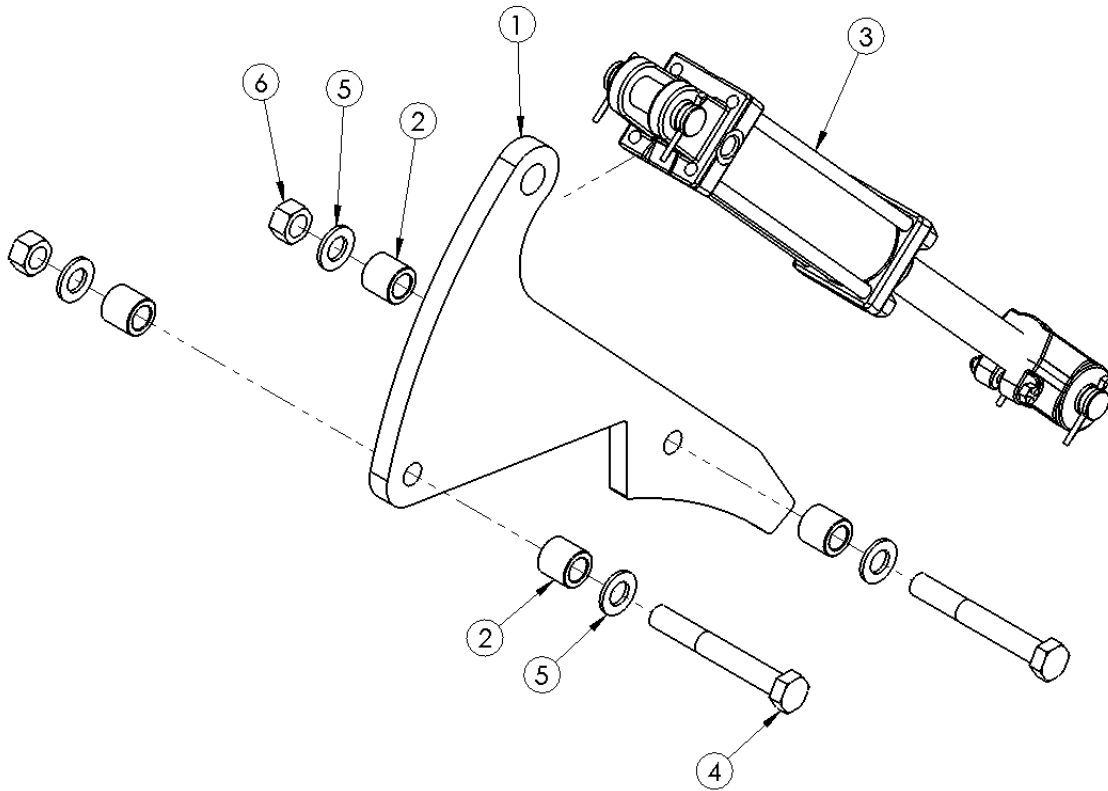

Item Number	Part #	Description	Quantity
1	333217	HYD TRIP CYLINDER PLATE	1
2	333115	1 1/4 BUSHING	4
3	333146	2 1/2 X 8 CYLINDER	1
4	411595	3/4-10 X 5.5 GR5 BOLT	2
5	413072	3/4 FLAT WASHER SAE	4
6	410012	3/4-10 NUT CENTER LOCK	2



HYDRAULIC TRIP - KNIFE PLATE

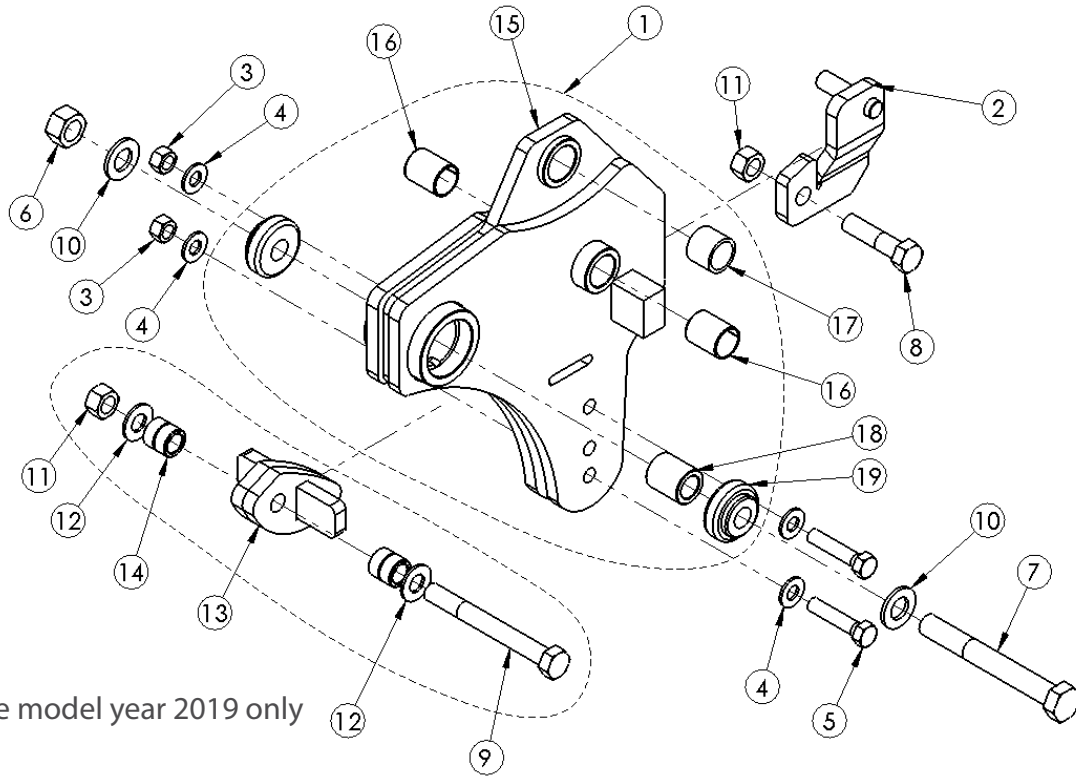

Item Number	Part #	Description	Quantity
1	333171	KNIFE PLATE ASSEMBLY	1
2	333130	PACKER SPRING BRACKET	1
3	412058	1/2-13 NUT GR5 Z/C	2
4	413007	1/2 FLAT WASHER SAE Z/C	4
5	411185	1/2-13 X 2 1/4 GR5 Z/C	2
6	410012	3/4-10 NUT CENTER LOCK Z/C	1
7	411597	3/4-10 X 6 GR 5	1
SEE NEXT PAGE FOR REMAINING PARTS LIST			



HYDRAULIC TRIP - KNIFE PLATE

Item Number	Part #	Description	Quantity
8	411562	5/8-11 X 2.5 GR.5	1
9	411569	5/8-11 X 5.5 GR.5	1
10	413072	3/4 FLAT WASHER SAE Z/C	2
11	410009	5/8-11 NUT CENTER LOCK GR2 Z/C	2
12	413011	5/8 FLAT WASHER SAE Z/C	2
13	333140	KNIFE PLATE STOP	1
14	333077	1" SLEEVE BEARING	4
15	333170	HYD TRIP KNIFE PLATE	1
16	333172	1 SLEEVE BUSHING	2
17	333208	1 1/4 BUSHING	1
18	333009	SPACER BUSHING	1
19	333010	3/4 BORE BEARING	2



HYDRRAULIC TRIPPING SYSTEM - ROW UNIT

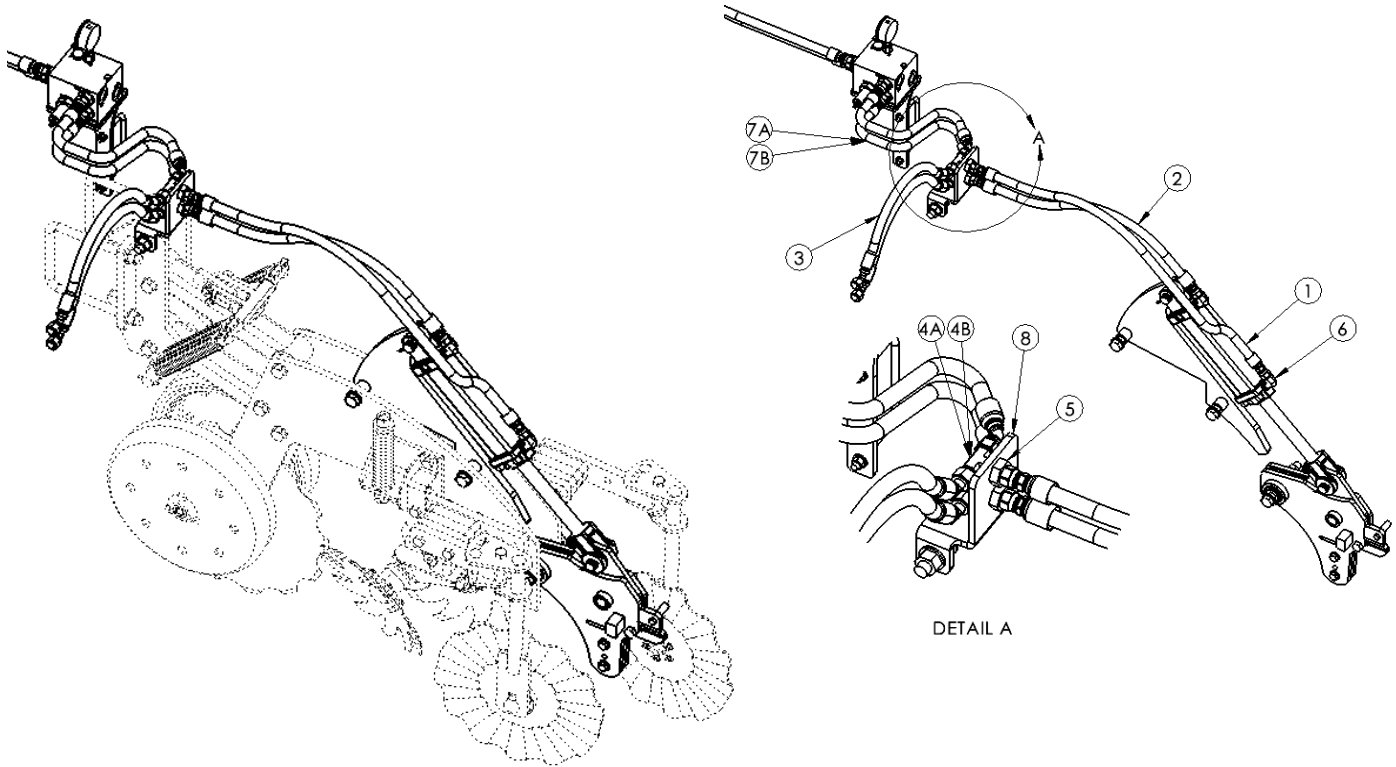

Item Number	Part #	Description
1	333230	40" 10 FJIC - 10 FJIC HOSE ASSEMBLY
2	333231	30" 10 FJIC - 10 FJIC HOSE ASSEMBLY
3	333232	20" 10 FEMALE 45 - 10 FEMALE 45 HOSE ASSEMBLY
4A	333226	FITTING BULKHEAD 10 NJIC TEE
4B	333225	FITTING BULKHEAD 10 MJIC - 10 MJIC ELBOW 90 (FOR END ROWS)
5	333227	FITTING BULKHEAD 7/8-14 NUT
6	333229	FITTING 8 MJIC - 8 MORB ELBOW 90
7A	333247	20/22/30" SPACING MANIFOLD TO BULKHEAD HOSE ASSEMBLY
7B	333249	36"-40" SPACING MANIFOLD TO BULKHEAD HOSE ASSEMBLY
8	333228	STRIPCAT™ HYDRAULIC TRIP MOUNT BRACKET ASSEMBLY



HYDRRAULIC TRIPPING SYSTEM - MANIFOLD TO TRACTOR (FOLDING)

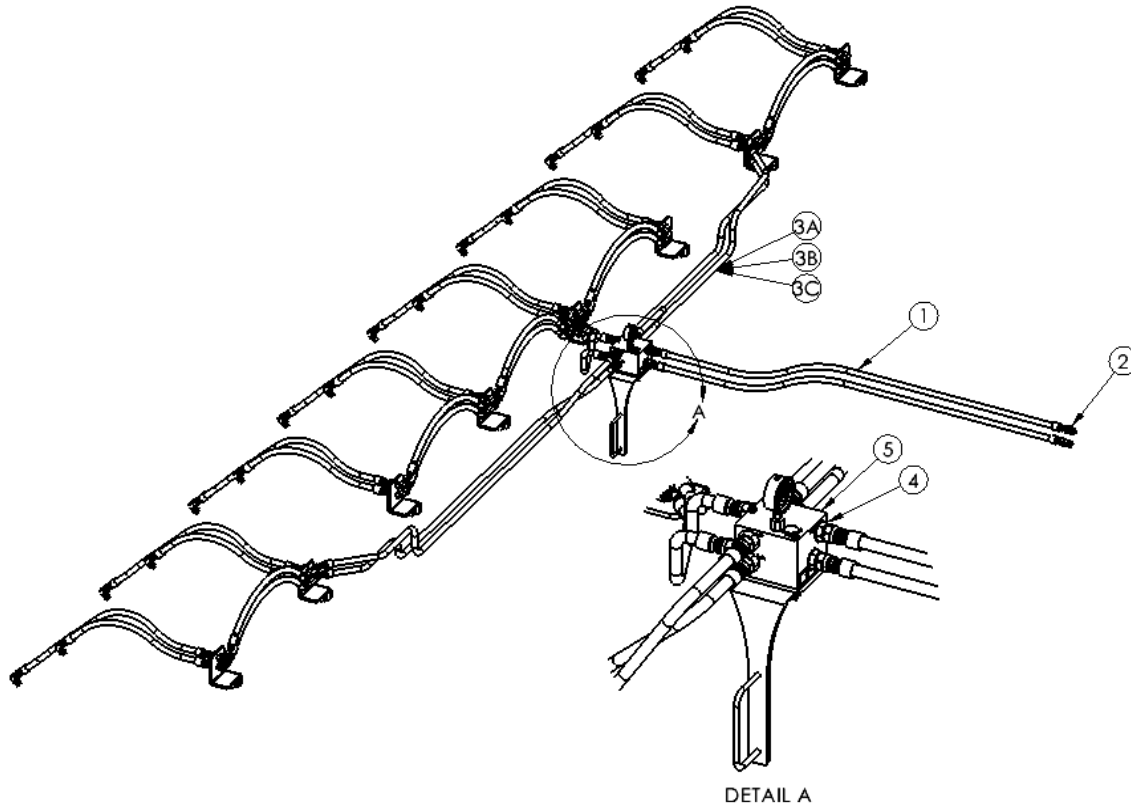

Item Number	Part #	Description
1	333246	HOSE ASSEMBLY 72" LONG 12 FJIC - 8 MORB
2	333245	8 ORB ISO TRACTOR 1/2" QUICK COUPLER
3A	333256	HOSE ASSEMBLY 8R30 AND 12R20/22 FOLDING MANIFOLD TO WINGS
3B	333258	HOSE ASSEMBLY 8R36-40 & 12R30 FOLDING MANIFOLD TO WINGS
3C	333259	HOSE ASSEMBLY 16R30 & 12R36-40 FOLDING MANIFOLD TO WINGS
4	333248	FITTING 12 FJIC TO 12 MORB COUPLER STRAIGHT
5	333242	STRIPCAT™ MANIFOLD BRACKET ASSEMBLY



HYDRRAULIC TRIPPING SYSTEM - MANIFOLD TO TRACTOR (RIGID)

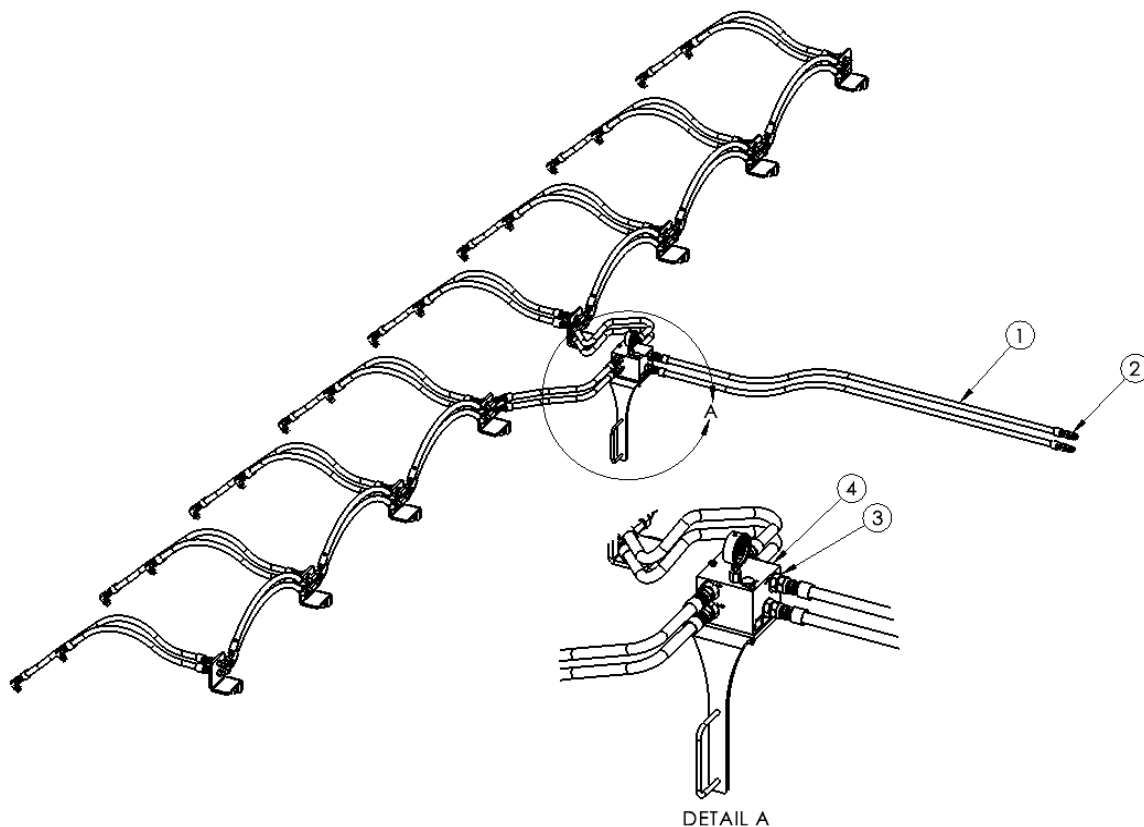

Item Number	Part #	Description
1	333246	HOSE ASSEMBLY 72" LONG 12 FJIC - 8 MORB
2	333245	8 ORB ISO TRACTOR 1/2" QUICK COUPLER
3	333248	FITTING 12 FJIC TO 12 MORB COUPLER STRAIGHT
4	333242	STRIPCAT™ MANIFOLD BRACKET ASSEMBLY



HYDRRAULIC TRIPPING SYSTEM - MANIFOLD & BRACKET PARTS

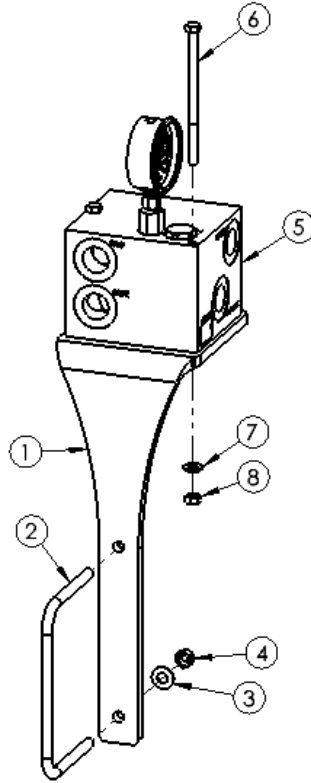

Item Number	Part #	Description
1	333244	STRIPCAT™ MANIFOLD BRACKET
2	415127	3/8-16 UBOLT 4W X 6H
3	413009	3/8 FLAT WASHER SAE
4	410006	3/8-16 NUT CENTER LOCK
5	333241	STRIPCAT™ MANIFOLD & GAUGE
6	411138	5/16-18 X 5 GR 5 BOLT
7	413005	5/16 FLAT WASHER SAE
8	412055	5/16-18 NUT CENTER LOCK



HYDRRAULIC TRIPPING SYSTEM - MOUNT BRACKET

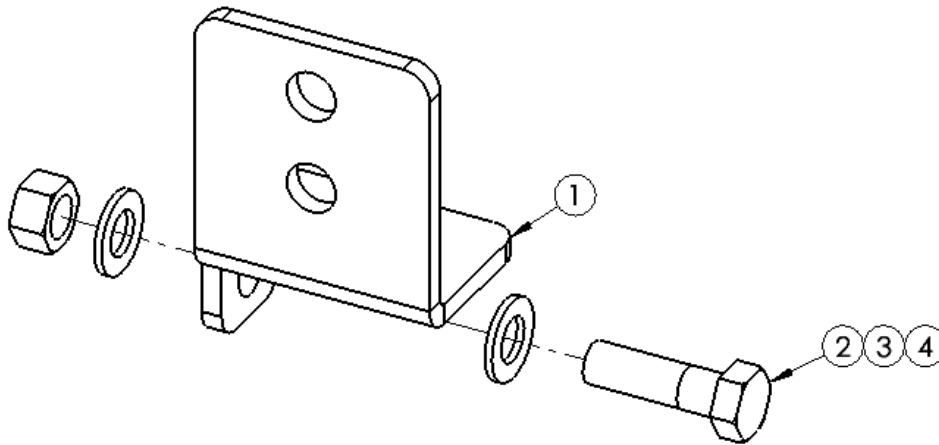

Item Number	Part #	Description
1	333224	STRIPCAT™ HYDRAULIC TRIP MOUNT BRACKET
2	411586	3/4-10 X 2-1/2 BOLT GR5 4W X 6H
3	413072	3/4 FLAT WASHER SAE
4	410012	3/4-10 NUT CENTER LOCK



STRIP FRESHENER DISC ASSEMBLY LEFT HAND 5 DOWN

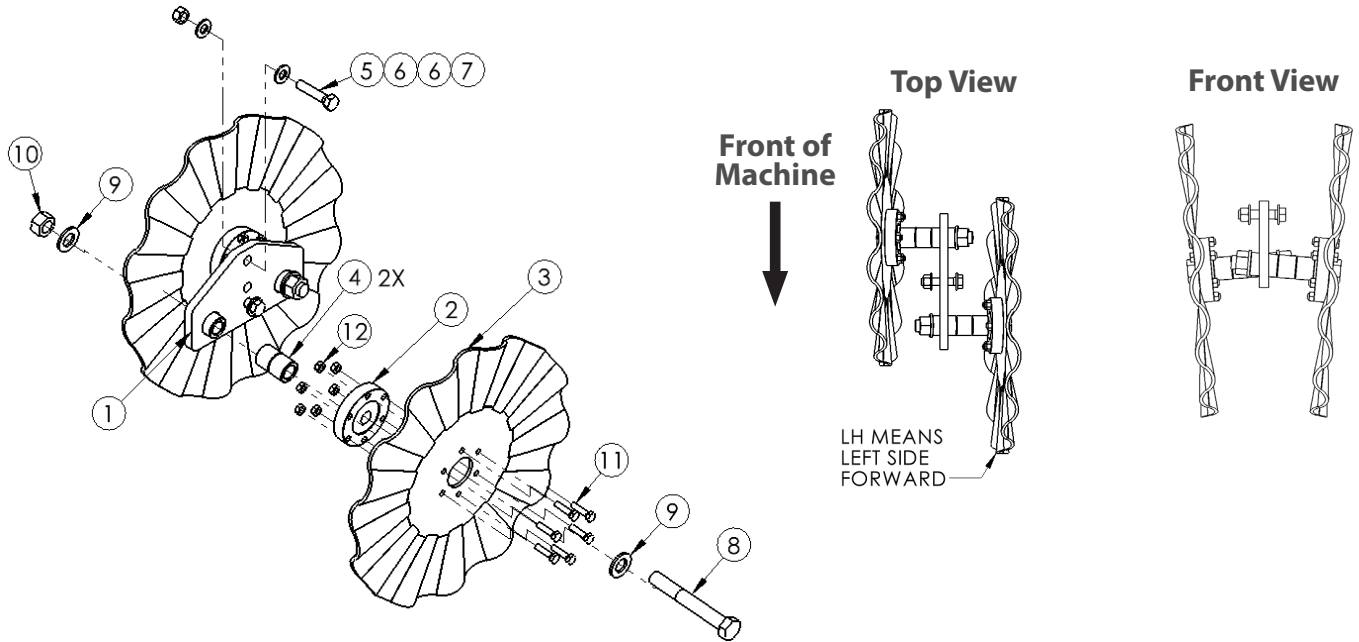

Item Number	Part #	Description	Quantity
1	333142	LH COULTER MOUNT 5 DOWN	1
2	333199	HUB ASSEMBLY	2
3	333118	16" WAVY COULTER BLADE	2
4	333141	REAR COULTER SPACERS	4
5	411185	1/2-13 X 2 1/4 GR5 BOLT	2
6	413007	1/2 FLAT WASHER SAE	4
7	412058	1/2-13 NUT GR5	2
8	411595	3/4-10 X 5 1/2 BOLT GR5	2
9	413072	3/4 FLAT WASHER SAE	4
10	410012	3/4-10 NUT CENTER LOCK	2
11	411122	5/16-18 X 1 1/4 BOLT GR5	12
12	412055	5/16-18 NUT CENTER LOCK	12



STRIP FRESHENER DISC ASSEMBLY RIGHT HAND 5 DOWN

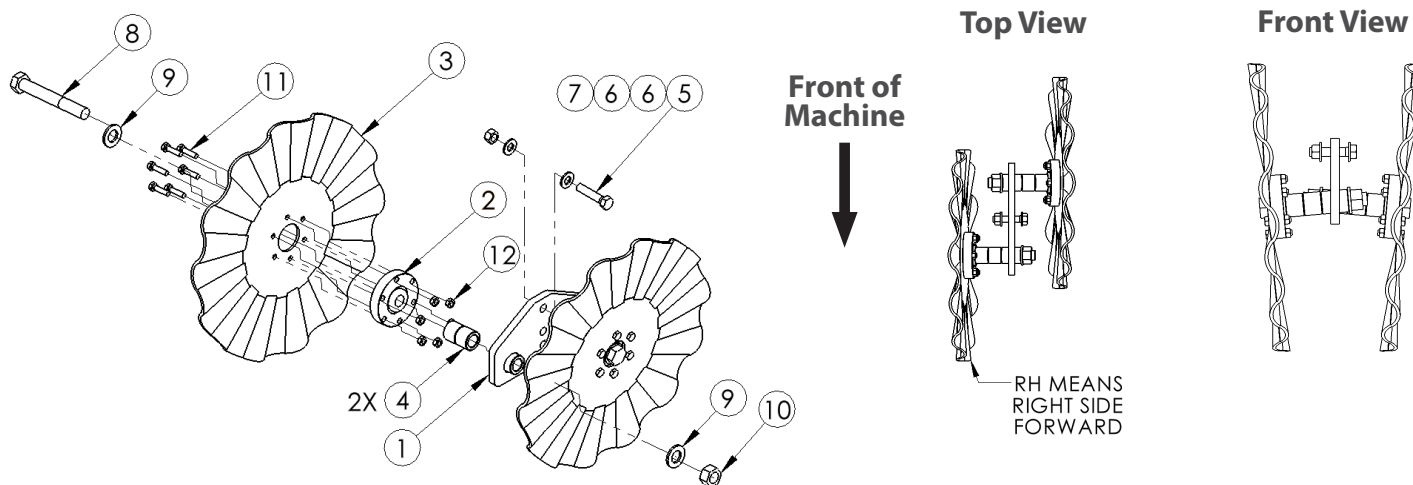

Item Number	Part #	Description	Quantity
1	333143	RH COULTER MOUNT 5 DOWN	1
2	333199	HUB ASSEMBLY	2
3	333118	16" WAVY COULTER BLADE	2
4	333141	REAR COULTER SPACERS	4
5	411185	1/2-13 X 2 1/4 GR5 BOLT	2
6	413007	1/2 FLAT WASHER SAE	4
7	412058	1/2-13 NUT GR5	2
8	411595	3/4-10 X 5 1/2 BOLT GR5	2
9	413072	3/4 FLAT WASHER SAE	4
10	410012	3/4-10 NUT CENTER LOCK	2
11	411122	5/16-18 X 1 1/4 BOLT GR5	12
12	412055	5/16-18 NUT CENTER LOCK	12



STRIP FRESHENER DISC ASSEMBLY LEFT HAND 5+5

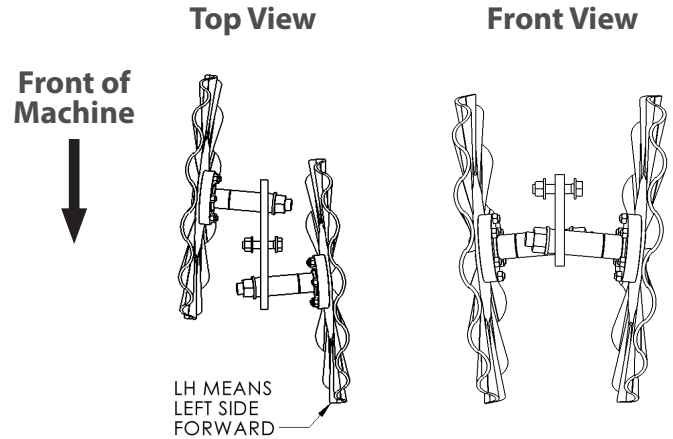
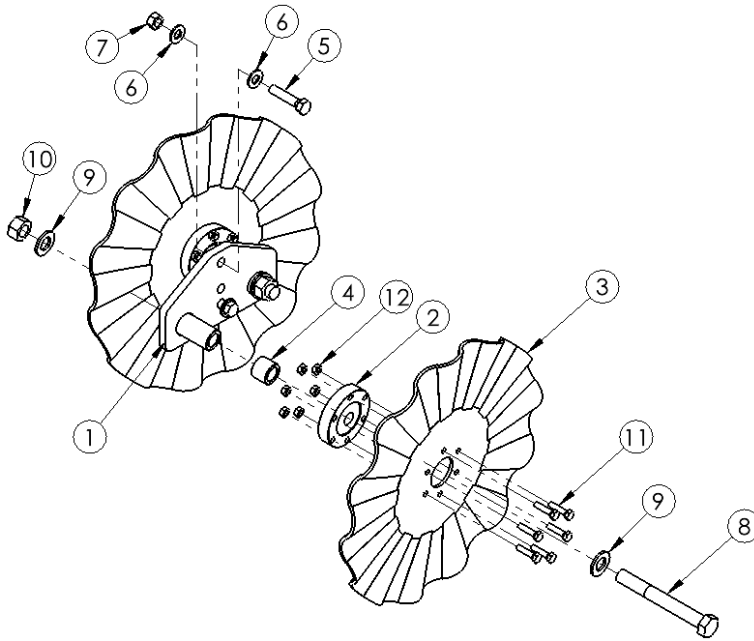

Item Number	Part #	Description	Quantity
1	333315	LH DUAL COULTER MOUNT 5+5	1
2	333199	HUB ASSEMBLY	2
3	333118	16" WAVY COULTER BLADE	2
4	333141	REAR COULTER SPACERS	4
5	411185	1/2-13 X 2 1/4 GR5 BOLT	2
6	413007	1/2 FLAT WASHER SAE	4
7	412058	1/2-13 NUT GR5	2
8	411597	3/4-10 X 6 BOLT GR5	2
9	413072	3/4 FLAT WASHER SAE	4
10	410012	3/4-10 NUT CENTER LOCK	2
11	411122	5/16-18 X 1 1/4 BOLT GR5	12
12	412055	5/16-18 NUT CENTER LOCK	12



STRIP FRESHENER DISC ASSEMBLY RIGHT HAND 5+5

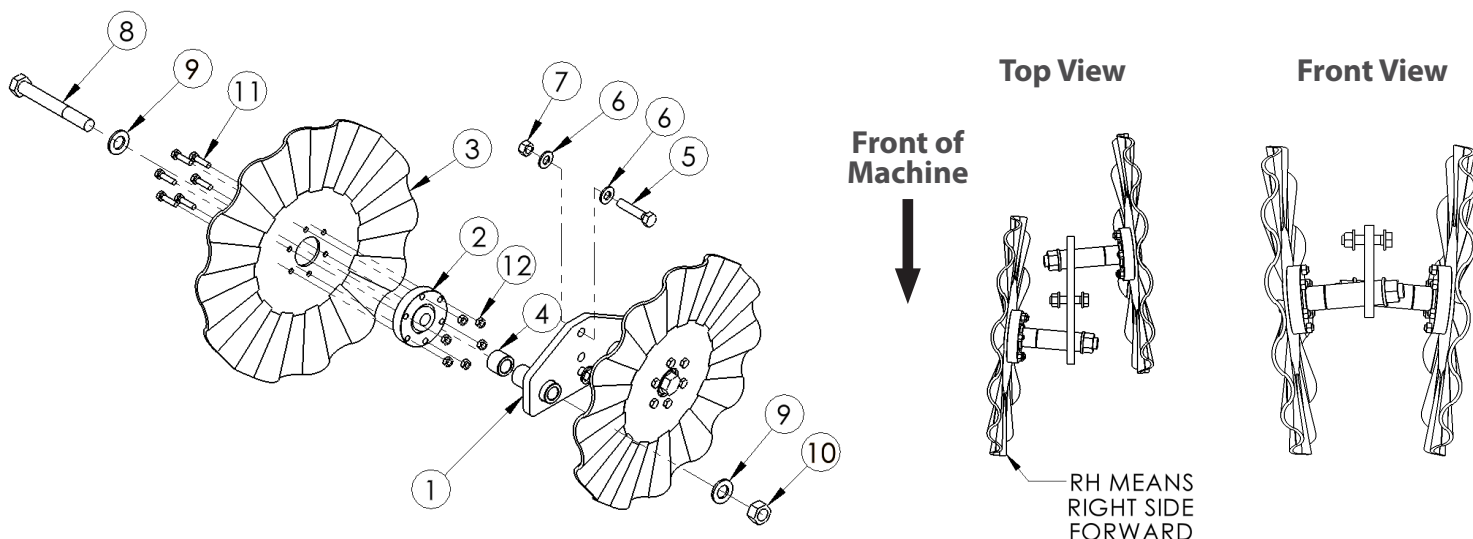

Item Number	Part #	Description	Quantity
1	333316	RH DUAL COULTER MOUNT 5+5	1
2	333199	HUB ASSEMBLY	2
3	333118	16" WAVY COULTER BLADE	2
4	333141	REAR COULTER SPACERS	4
5	411185	1/2-13 X 2 1/4 GR5 BOLT	2
6	413007	1/2 FLAT WASHER SAE	4
7	412058	1/2-13 NUT GR5	2
8	411597	3/4-10 X 6 BOLT GR5	2
9	413072	3/4 FLAT WASHER SAE	4
10	410012	3/4-10 NUT CENTER LOCK	2
11	411122	5/16-18 X 1 1/4 BOLT GR5	12
12	412055	5/16-18 NUT CENTER LOCK	12



HAWKINS

308.708.8185 | HAWKINSAG.COM
2120 4TH AVE, HOLDREGE, NE 68949